

COLLIER TOWNSHIP MUNICIPAL AUTHORITY

Short Form Specification

SANITARY SEWER CONSTRUCTION

**ADOPTED 3/12/93
REVISED 1/9/03
REVISED April, 2007**

BY:



**NIRA Consulting Engineers, Inc.
950 Fifth Avenue
Coraopolis, Pennsylvania 15108**

**Telephone: (412) 262-3970
Facsimile: (412) 262-1938
Email: mail@niraengineers.com
Web Site: www.niraengineers.com**

**COLLIER TOWNSHIP MUNICIPAL AUTHORITY
SHORT FORM SPECIFICATION
FOR SANITARY SEWER CONSTRUCTION**

TABLE OF CONTENTS

<u>SECTION</u>	<u>TITLE</u>	<u>PAGE NUMBER</u>
1.0	Scope	TS-1
2.0	General	TS-1
3.0	Quality Assurance (Submittals and Shop Drawings)	TS-1
4.0	Trenching and Pipe Bedding	TS-2
5.0	Pipe	TS-2
6.0	Polyethylene Encasement of Ductile Iron Pipe	TS-3
7.0	Joint Restraint	TS-3
8.0	Casing Spacers	TS-3
9.0	Casing End Seals	TS-3
10.0	Precast Sectional Reinforced Concrete Manholes and Precast Manhole Bases	TS-4
11.0	Manhole Steps	TS-4
12.0	Manhole Frames and Covers	TS-5
13.0	Manhole Inserts (Sewer Guards)	TS-5
14.0	Underground Early Warning Detection Tape	TS-5
15.0	Cement Concrete and Ready-Mixed Cement Concrete	TS-5
16.0	Stream Crossings and Concrete Encasement	TS-5
17.0	Backfilling	TS-6
18.0	Pipe Connections to Existing Manholes	TS-6
19.0	Drop Manhole Connections	TS-7

**COLLIER TOWNSHIP MUNICIPAL AUTHORITY
SHORT FORM SPECIFICATION
FOR SANITARY SEWER CONSTRUCTION**

**TABLE OF CONTENTS
(continued)**

SECTION	TITLE	PAGE NUMBER
20.0	Pipe Testing	TS-7
21.0	Vacuum Testing of Manholes	TS-8
22.0	Ground Surface Restoration	TS-8
23.0	Inspection of Work	TS-9
24.0	As-Built Drawings	TS-9

STANDARD DETAIL DRAWINGS:

- Trench Excavation Detail
- 48" \varnothing Precast Concrete Manhole
- 60" \varnothing Precast Concrete Manhole
- Standard Manhole Frame & Cover
- Water-Tight Manhole Frame & Cover
- Pre cast Concrete Manhole Base Detail
- Outside Drop Manhole Connection
- Inside Drop Manhole Connection
- Connection to Existing Precast Manhole
- Connection to Existing Brick Manhole
- Lamphole Detail
- Sanitary Sewer Lateral Installation (Interior Trap)
- Sanitary Sewer Lateral Installation (Exterior Trap)
- Lateral Fresh Air Vent on Elevated Grades at Driveways
- Lateral Air Vent in Driveways
- Lateral Disconnect From Septic System
- Standard 6" Sanitary Sewer Service Connection
- New Service Wye/Lateral connection to existing pipe
- Sanitary Sewer Typical Bore Detail
- Casing & Support Details for Boring
- Sanitary Sewer Concrete Encasement
- Concrete Pipe Anchor
- Trench Plug
- Grinder Pump to Gravity Sewer Main
- Grinder Pump to Low Pressure Sanitary Sewer
- Grease Interceptor System (Inside Building)
- Grease Interceptor System (Outside Building)
- Downspout Removal from Sanitary Sewers
- Stairwell Drain Removal from Sanitary Sewers
- Permanent Vegetative Restoration Detail
- Stream Bank Protection Detail
- Driveway Drain Removal from Sanitary Sewers

COLLIER TOWNSHIP MUNICIPAL AUTHORITY

SHORT FORM SPECIFICATION

FOR SANITARY SEWER CONSTRUCTION

1.0 SCOPE

These Specifications have been developed as a guide to assist Developers, Designers and Contractors involved in planning, designing and constructing sanitary sewerage facilities under the jurisdiction of The Collier Township Municipal Authority. It should be understood that these Specifications are general in nature and are not intended to address all conditions or needs of a particular project. Special circumstances which are peculiar to individual projects may require special design considerations. Developers and Designers of proposed sanitary sewerage facilities are encouraged to consult with The Municipal Authority and/or its Authorized Representatives regarding specific problems or unusual circumstances which may arise in the planning, design or construction of such facilities.

The work covered by these Specifications consists of furnishing all labor, equipment, and materials, including all pipe, materials for joint connection, manholes, service lines and completing all construction as shown on the Drawings or as specified herein.

2.0 GENERAL

Pipes and joints for the various types of sewer lines shall be of the materials indicated herein. Pipe shall be laid true to the grades shown on the Drawings or as directed by the Authority or the Authority's Authorized Representative. All sewer mains shall be installed by utilizing laser equipment designed for the intended purpose. Laser equipment shall be checked for accuracy of grade and calibrated as required by the Authority or the Authority's Authorized Representative. Each section of pipe shall rest upon the pipe bed for the full length of its barrel, with recesses to accommodate bells and joints. Any pipe that has its grade or joint disturbed after laying shall be taken up and re-laid. The interior of all pipe shall be thoroughly cleaned of all foreign matter before being lowered into the trench and shall be kept clean during laying operation by means of plugs or other approved methods. Any section of pipe already laid and found to be defective, shall be removed and replaced with new pipe.

3.0 QUALITY ASSURANCE (SUBMITTALS AND SHOP DRAWINGS)

To ensure that the specified products are furnished and installed, submittals, including manufacturer's certificates, shop drawings, brochures, product samples and catalog cuts for all products and materials to be used in connection with the project shall be submitted to the Authority or the Authority's Authorized Representative. All submittals shall be submitted in quadruplicate and shall be submitted sufficiently in advance of the purchase of such materials to permit review of the submittals by the Authority or the Authority's Authorized Representative. No substitution of materials or equipment shall be permitted without written approval of the Authority or the Authority's Authorized Representative.

4.0 TRENCHING AND PIPE BEDDING

The side walls of the trench shall be kept as nearly vertical as possible and shall be properly shored and braced. Trenches shall be excavated true to line and grade so that a clear space of not less than four (4) inches and not more than eight (8) inches is provided on either side of the barrel of the pipe.

All pipe trench excavation shall be made to a minimum depth of four (4) inches beneath the pipe. The pipe shall then be bedded in crushed stone or cracked gravel bedding material in accordance with the requirements for Class B, First Class AASHTO # 57 Bedding material in accordance with A.S.T.M. Designation C-12 latest edition, and conforming with the applicable Standard Detail Drawings.

Where rock excavation is encountered, the rock shall be excavated a minimum overdepth of six (6) inches below the trench depths specified. The overdepth rock excavation and all excessive trench excavation shall be backfilled with Class B, First Class AASHTO # 57 Bedding material in accordance with A.S.T.M. Designation C-12 latest edition. All aggregate materials shall meet Pennsylvania Department of Transportation Specifications Publication 408, latest edition.

Where quicksand, muck or other such conditions exist, which results in an unstable trench bottom, tongue and groove sheet piling, timber piles and/or over excavation and backfilling with selected borrow material may be required. The type and extent of methods employed to stabilize the trench bottom shall be approved by the Authority or the Authority's Authorized Representative.

All ground water which may be found in the trenches and any water which may get into them from any cause whatsoever, shall be pumped or bailed out so that the trench shall be dry during pipe laying period. No water shall be permitted to reach the joints or run through the pipe. All water pumped from the trenches shall be disposed of in a satisfactory manner.

5.0 PIPE

5.1 Polyvinyl Chloride (PVC)

PVC Pipe and fittings shall be bell and spigot type, free from defects and shall conform in all respects to A.S.T.M. Designation D-3034-SDR-35.

5.2 Ductile Iron Pipe

Ductile Iron Pipe shall be AWWA C151 special thickness Class 52, bell and spigot type, free from defects and shall conform in all respects to AWWA C150 and C151. The inside of the Pipe and Fittings shall be coated with Protecto 401 ceramic Epoxy lining at a nominal thickness of 40 mils or approved equal. The pipe and fittings shall be asphalt coated on the outside in accordance with AWWA C104. All Ductile Iron Pipe shall be not less than special thickness Class 52, except where a higher pressure class may be required by the Authority or the Authority's Authorized Representative.

5.3 Steel Casing Pipe

Steel casing pipe shall be welded steel pipe, manufactured and tested in accordance with A.S.T.M. A-53, Grade B, with a minimum yield strength of 35,000 psi. The pipe shall be new, visibly sound and round. Minimum casing wall thickness shall be as follows:

<u>NOMINAL DIAMETER OF CASING PIPE IN INCHES</u>	<u>WALL THICKNESS</u>
Under 14	0.251"
14 and 16	0.282"
18	0.313"
20	0.344"
22	0.375"
24	0.407"
26	0.438"
28 and 30	0.469"
32	0.501"
34 and 36	0.532"

6.0 POLYETHYLENE ENCASEMENT OF DUCTILE IRON PIPE

Where the Authority or its Authorized Representative requires the use of ductile iron pipe for reasons of depth of cover, high external loading, steep slopes or other physical circumstances, the exterior of the ductile iron pipe and fittings shall be encased in polyethylene film Wrap with a minimum nominal thickness of 8 Mils or approved equal in accordance with ANSI/ASTM D-1248 and with AWWA Standard C105 "Polyethylene Encasement for Ductile Iron Piping for Water and Other Liquids."

7.0 JOINT RESTRAINT

Where sewer lines are installed on steep slopes, the Authority or the Authority's Authorized Representative may require, in addition to pipe anchors, the use of joint restraint mechanisms which may include but are not limited to approved field locking gaskets for ductile iron pipe or bell joint restrainers for PVC pipe.

8.0 CASING SPACERS

Where sewer lines are installed by boring, the sewer pipe shall be placed in a steel casing pipe and shall be supported by casing spacers constructed of high molecular weight polymer runners secured to a stainless steel shell, as manufactured by Cascade Water Works Mfg. Co. of Yorkville, IL. Not less than three (3) spacers shall be used on each pipe length.

9.0 CASING END SEALS

Casing pipe end seals of the required size shall consist of a rubber seal and two (2) T-304 stainless steel bands, as manufactured by Cascade Water Works Mfg. Co. of Yorkville, IL.

10.0 PRECAST SECTIONAL REINFORCED CONCRETE MANHOLES AND PRECAST MANHOLE BASES

All manholes sections shall be reinforced precast concrete and shall conform to A.S.T.M. Designation C-478, latest revision. Manhole joints shall have two (2) ¾ -inch wide rings of "Kent-Seal" No. 2 or conseal CS-202 flexible BUTYL sealant to insure water tightness conforming to A.S.T.M. Designation C-361 and C-443 latest revision ASSHTO M-198. Manholes shall provide a watertight pipe to manhole connection. The pipe to manhole connection shall consist of either:

1. A standard rubber connector gasket integrally cast within the manhole wall. Use A-LOK brand X-CEL, or approved equal, conforming to all material and test requirements outlined in ASTM C-923
2. An integrally cast boot complete with stainless steel banding and clamp. Use A-LOK brand Z-LOK, or approved equal, conforming to all material and test requirements outlined in ASTM C-923.
3. A positive seal gasket with expanded sleeve and stainless steel banding and clamp. Use PSX Manhole Connector, or approved equal, conforming to all material and testing requirements outlined in ASTM C-923.

All manholes shall be watertight and infiltration proof as possible. Openings through the manhole walls shall be plugged with "Thorite General Purpose Mortar with Acryl 160 Additive or approved equal. Any noticeable ground water leakage into the manhole shall be repaired in a manner satisfactory to the Authority or the Authority's Authorized Representative.

Manhole flow line channels shall be molded in the floor of the precast concrete base and shall be finished smooth sloping from the influent pipe invert to the effluent pipe invert. The elevation difference between manhole pipe inverts shall conform to the approved design profiles, however, the minimum elevation difference between influent and effluent pipe inverts shall never be less than 0.20 vertical feet. Pipes projecting into manholes shall not project more than two inches (2") beyond the interior wall surface of the manhole. Concrete used for this purpose shall meet the Pennsylvania Department of Transportation, Form 408 Specifications for Class A concrete.

XYPEX

Manhole concrete shall contain Xypex Admix C-1000 at a rate of 2-3% by weight of cement. The Xypex shall be blended into the concrete at the time of batching. Xypex Admix C-2000 at a rate of 2% by weight of cement may be required where extended retardation is desired.

11.0 MANHOLE STEPS

Manhole steps shall be placed on not less than twelve (12) inch centers, but not more than sixteen (16) inch centers. The steps shall be placed along the straight side of the manhole and shall be properly aligned. The steps shall be reinforced polypropylene plastic, as manufactured by M.A. Industries, Inc., Type PS-4 or equal and shall conform in all respects to A.S.T.M. 2146-68 Type II Grade 49108. The steel shall be a deformed 3/8 inch reinforced rod, Grade 60 conforming to A.S.T.M. A-615.

12.0 MANHOLE FRAMES AND COVERS

All castings for manhole heads, covers, and other purposes must be tough gray iron, free from cracks, holes, swells, and cold shuts.

The quality shall be such that a blow from the hammer will produce an indentation on a rectangular edge of the casting without flaking the metal. All manhole castings shall be made accurately to the pattern and to the dimensions shown on the Drawings and shall be planned where marked or where otherwise necessary to secure perfectly flat and true surfaces.

Allowances shall be made in the patterns so that the thickness shall not be reduced. All lids which "rock" and do not lie solid after construction is finished, will be condemned and must be replaced by perfect lids. No plugging, burning in, or filling will be allowed. Covers must fit the frames in any position. All manhole covers shall be marked as shown on the applicable Standard Detail Drawing.

Frames shall be bolted down to top section of manhole and shall have two (2) rows of ¾ inch wide "KENT-SEAL" No. 2 or "Conseal" CS-202 flexible BUTYL sealant placed between casting and manhole before securing.

13.0 MANHOLE INSERTS (SEWER GUARDS)

Where manholes are located in paved areas or for any reason may be subject to inflow of surface water, a watertight manhole insert shall be provided and installed to prevent inflow of such surface water into the manhole through the manhole cover. Manhole inserts shall be the "Rainstopper" Manhole Insert, as manufactured by Southwestern Packing & Seals, Inc., Shreveport, LA or equal.

14.0 UNDERGROUND EARLY WARNING DETECTION TAPE

Install underground early warning detection tape as indicated on the Detail Drawing. Tape shall be installed above all sewer lines installed and as shown on the applicable Standard Detail.

The tape shall be equal to Detectable Underground Marking Tapes, as manufactured by Pro-Line Safety Products. Tape shall be six (6) inches wide, green, and shall state, "Caution Sanitary Sewer Line Buried Below."

15.0 CEMENT CONCRETE AND READY-MIXED CEMENT CONCRETE

Cement concrete and ready-mixed cement concrete shall be Class A conforming to Section 704 of the Pennsylvania Department of Transportation Specifications, Form 408.

16.0 STREAM CROSSINGS AND CONCRETE ENCASEMENT

Pipeline stream crossings shall be constructed in accordance with the following specifications and with all Pennsylvania DEP and Allegheny County Conservation District requirements.

Concrete encase the sewer pipe a minimum of five feet (5') beyond the stream edges. Provide a minimum of six inches (6") of Penn DOT Class A Cement Concrete around the pipe O. D. and

reinforce as shown on the Standard Detail. Backfill with a minimum size of Penn DOT R-3 crushed limestone to the level of the stream bed between the limits of the stream crossing.

17.0 BACKFILLING

Caution in all cases of earth filling and backfilling shall be exercised in insuring that it is not done prematurely and that no pressure against which the construction has not been designed to withstand is exerted thereby. Any movement of the structure incident to neglect or failure in such exercise of caution shall be promptly, fully corrected.

The area to be backfilled shall be cleared of all trash and debris prior to backfilling. Material for backfilling shall consist of the excavation or borrow of sand, gravel, or other materials approved by the Authority or the Authority's Authorized Representative, and shall be free of trash, lumber and other debris. Backfill shall be placed in horizontal layers not in excess of six (6) inches in thickness, properly moistened to approximate optimum requirements and each layer compacted by vibrator tampers, machine tampers, or other suitable equipment to not less than 95 percent of the determined dry weight density.

Backfill to 12" above the crown of the pipe shall be with AASHTO # 57 coarse aggregate hand placed and carefully compacted with hand-operated mechanical tampers in layers of suitable thickness to provide specified compaction around and under the haunches of the pipe. All aggregate materials shall meet Pennsylvania Department of Transportation Specifications Publication 408, latest edition.

All pipe trenches crossing Roadways, Driveways etc. shall be backfilled with Penn Dot #2A select Granular Aggregate Materials from the top of the Pipe Bedding up to the Roadway or Driveway pavement structure. Backfill compaction shall be performed in accordance with this section.

Puddling will not be permitted.

18.0 NEW PIPE CONNECTIONS TO EXISTING MANHOLES

18.1 Precast Manholes:

New pipe connections to existing precast manholes shall be made by core boring a neat circular hole in the wall of the manhole. Install the proper size PSX Manhole Connector as manufactured by Press-Seal Gasket Corporation, or approved equal. Insert a length of sewer pipe through the connector and, when directed by the Engineer, fill around the pipe with Thorite General Purpose Mortar with Acryl 60 additive, or approved equal. Shape the invert of the manhole to accommodate the invert of the pipe with Thorite General Purpose Mortar with Acryl 60 additive or equal.

18.2 Brick Manholes:

Remove a minimal amount of brick by core boring a hole in the manhole wall. Fill all voids in manhole wall with Thorite General Purpose Mortar with Acryl 60 additive or approved equal. Manhole wall must be clean and smooth prior to installation of pipe to manhole adaptor. Install the proper size Sanded Manhole Adaptor as manufactured by GPK Products, Inc. Fill around the adaptor with Thorite General Purpose Mortar with Acryl 60 or approved equal. Shape the invert of the manhole to accommodate the invert of the pipe with Thorite General Purpose Mortar with Acryl 60 additive or equal.

Drop manhole connections to existing manholes shall be constructed as outlined above and as shown on the Standard Details.

19.0 DROP MANHOLE CONNECTIONS

The installation of drop manhole connections will only be allowed when excavating to the depth required to install a conventional connection is not practical. The Authority or Authority's Representative shall make this determination. When an inside drop manhole connection is proposed, a 60-inch diameter manhole will be required for all new sanitary sewer installations (see Standard Detail for installation requirements). An outside drop manhole connection will be allowed for connections to existing manholes (see Standard Detail for installation requirements).

20.0 PIPE TESTING

20.1 Low Pressure Air Testing for Leakage

All sewer pipe shall be tested by means of a low pressure air test. The final air test shall not be made until all service laterals have been installed up to the property line or edge of the easement, as the case may be. All air testing shall be performed prior to any permanent surface restoration.

The Contractor shall plug and brace the ends of the sewer lines being tested. At his option, the Contractor may conduct an initial air test of the sewer main line after densification of the backfill, but prior to installation of the house laterals. Such preliminary tests shall not constitute a final test.

The final leakage test shall be conducted in the following manner, and shall include both the sewer main line and laterals:

Add air slowly to the portion of the pipe installation under test until the internal air pressure is raised to 5.0 psig.

After an internal pressure of 5.0 psig is obtained, allow at least two (2) minutes for air temperature to stabilize, adding only the amount of air required to maintain 5.0 psig internal pressure.

After stabilization, the portion of the pipe installation under test must maintain an internal pressure of 5 psig without loss for a minimum period of five (5) minutes.

If pressure loss occurs within the stated five (5) minute period, the pipe section under test shall have failed to meet the requirements of these Specifications and the Contractor shall make such repairs as are necessary in order to meet these Specifications.

The input air pressure shall not exceed 10 psig, utilizing a regulator set to avoid over-pressurizing and damaging an otherwise acceptable line.

The air testing equipment shall be approved by the Authority or the Authority's Authorized Representative.

20.2 Deflection Test for PVC Pipe

The installed sewer line shall meet a deflection requirement of less than five (5) percent by the use of a go/no-go gauge pulled through the line. This test shall be performed three (3) months after installation. The go/no-go gauge shall be supplied by the pipe manufacturer. The deflection test shall be performed on 100 percent of the sewer system.

21.0 VACUUM TESTING OF MANHOLES

All new manholes shall be vacuum tested in accordance with the following procedure:

Plug all pipe openings. Take care to securely brace the plugs and pipe. Inflate the compression band to effect a seal between the vacuum base and the structure. Connect the vacuum pump to the outlet port with the valve open. Draw a vacuum to 10" of Hg. Close the valve. Start the test and maintain for 60 seconds. Record the vacuum drop during the test period. If the vacuum drop is greater than 1.0" of Hg. during the test period, the manhole shall be repaired and retested. If a vacuum drop of 1" of Hg. does not occur during the test period, the test shall be discontinued and the manhole will be accepted. If the loss of vacuum exceeds 1" of Hg., repair leaks and retest.

If a unit fails to meet a 1" Hg. drop in the specified time after repair, the unit shall be subjected to the water exfiltration test and repaired as necessary as directed by the Authority or the Authority's Authorized Representative.

22.0 SURFACE RESTORATION

All ground surfaces disturbed while installing main line sewers or lateral connections must be restored to a condition equal to or better than the original surface condition.

22.1 Topsoil Furnished and Placed

Topsoil shall conform to Section 802 of the Pennsylvania Department of Transportation Specifications Form 408, latest edition.

Grade the areas to be covered by topsoil. Using acceptable methods, loosen soil to a depth of 50 mm (2 inches) before placing the topsoil. Remove stones and other foreign material 50 mm (2 inches) or larger in any dimension. Remove and satisfactorily dispose of unsuitable and surplus material.

Place topsoil on the prepared areas and, unless otherwise indicated, spread and compact to a 100 mm (4-inch) uniform depth. Compact with a roller having a mass (weight) not over 180 kg/m (120 pounds per foot) width of roller or by other acceptable methods, as directed. Remove overdepth topsoil, unless otherwise agreed upon in writing. Do not place topsoil in a wet or frozen condition.

22.2 Seeding and soil supplements

Seeding and soil supplements shall conform to Section 804 of the Pennsylvania Department of Transportation Specifications Form 408, latest edition. Seed mixture shall be Formula "D" and/or Formula "B" as directed by the Engineer. Formula "B" and/or Formula "D" shall be sown at the rate of 21 pounds per 1,000 square yards. Lime shall be applied at the rate of 800 pounds per 1,000 square yards and 10-20-20 commercial fertilizer at the rate of 192 pounds per 1,000 square yards.

Straw mulching shall be used in accordance with Section 805 of the Pennsylvania Department of Transportation Specifications Form 408, latest edition.

The Contractor will be responsible for securing a good catch of seed and seedlings. Damages arising from improper adherence to above conditions will be the responsibility of the Contractor.

The Contractor shall be responsible for a satisfactory growth of the various seed formulas within the areas of restoration until the expiration date of the Maintenance Bond.

- 22.3** All Pavements or Cartway structures shall be restored to a depth and to a condition equal to or better than the existing pavement structure. All Township, County and State Roadway Pavements disturbed by excavation must be restored in accordance with the respective Agency's Standards.

23.0 INSPECTION OF WORK

All materials and workmanship shall be subject to inspection, examination, or test by the Authority or the Authority's Authorized Representative at any and all times during manufacture or construction and at any and all places where such manufacture or construction is carried on. The Authority or the Authority's Authorized Representative shall have the right to reject defective material and workmanship or require its correction. Unacceptable workmanship shall be satisfactorily corrected. Rejected material shall be promptly segregated and removed from the construction site and replaced with material of specified quality.

The Authority or the Authority's Authorized Representative and governmental agencies with jurisdictional interests will have access to the work at reasonable times for their observation, inspection and testing. The Contractor shall provide proper and safe conditions for such access.

The Contractor shall give ample notice to the Authority or the Authority's Authorized Representative before laying pipe so that an Inspector may make proper inspection. All pipe, before being lowered into the trench, shall be inspected and both ends shall be cleaned.

Before backfilling is begun, the Contractor shall make tests as directed by the Authority or the Authority's Authorized Representative in order to ascertain if joints are tight. Leaking, poor or misaligned joints shall be removed or repaired at once.

Further tests of the installation of sewers shall be made as follows:

After the mains have been laid and backfill placed to two (2) feet above the pipe, a light will be flashed between manholes or, if the manhole has not yet been constructed, between the location of manholes, by means of a flashlight or mirrored light to determine whether the alignment of the main is true and whether any pipe has been displaced subsequent to laying.

In case the alignment of the main is shown to be correct and no other defects are disclosed, backfilling may be continued. In case the test shows poor alignment of the main, misplaced pipe or other defects, such defects shall be remedied by the Contractor, to the satisfaction of the Authority or the Authority's Authorized Representative, before the work of backfilling proceeds.

24.0 AS-BUILT DRAWINGS

At the completion of the project and prior to the final acceptance of any facilities by the Authority or the Authority's Authorized Representative, accurate As-built Drawings or electronic files, including plans and profiles shall be provided to the Authority or the Authority's Authorized Representative. As-built Drawings shall be reproducible mylars or computer diskette in an approved CAD or Arc View format and shall include the field measured horizontal angles and distances between the centerline of each successive manhole. All distances shall be recorded to the nearest one hundredth of a foot. The size and type of pipe for each section of the sewer line shall be clearly noted. The profiles shall include each manhole top, flow line-in and flow line-out elevation. All elevations shall be based on and tied to the North American Vertical Datum of 1983 – NAD 83 (1986).

The as-built plans shall accurately demonstrate the location of all wyes and service connections. The as-built stationing of all wyes shall be recorded on the plan and may be included in a table in a tabular format which identifies the location (left or right) and the station of each wye, as measured from the centerline of the sanitary manhole located immediately downstream of the wye. The plans shall also include the stationing and perpendicular offset, indicating whether left or right, for the end of all service lines. The size, type and depth at the end of each service line shall also be indicated. The relative location, depth and approximate clearance of other underground utilities and/or structures in close proximity of the sewer lines and manholes shall be included on the As-built Drawings. Any revisions or additional information, which may be required, shall be subsequently provided by the Contractor.

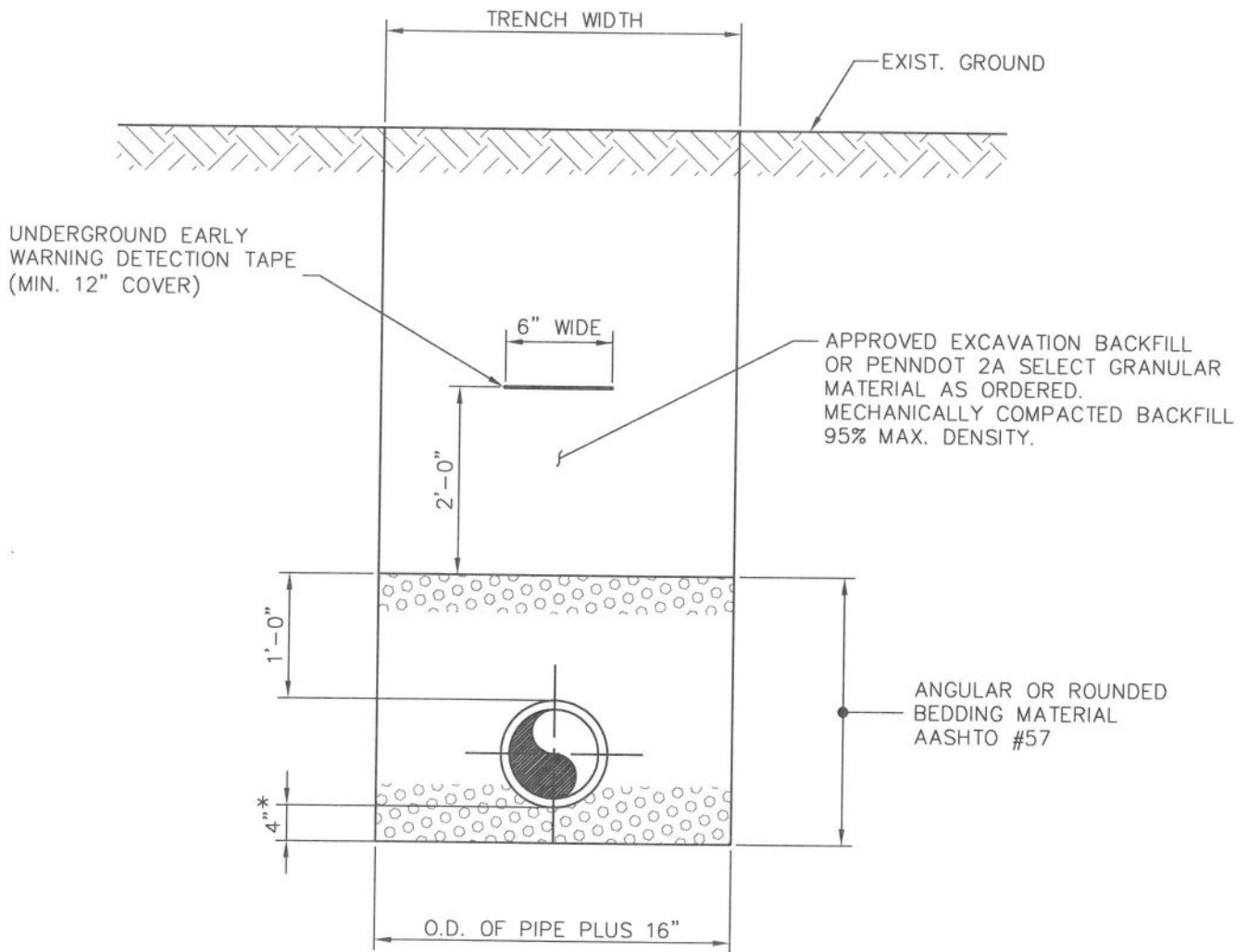

* = 6" OVERBREAK IN ROCK OR UNSUITABLE MATERIAL

SANITARY SEWER
TRENCH EXCAVATION DETAIL

NIRA Consulting Engineers, Inc.

2 (TWO) RINGS OF 3/4" WIDE
 CONSEAL CS-202 BUTYL RUBBER
 SEALANT CONTINUOUS ABOUT INNER
 & OUTER PERIMETER OF FRAME &
 MANHOLE INTERFACE

MANHOLE FRAME & COVER
 (SEE DETAIL)

ANCHOR FRAME
 TO MASONRY

PRECAST CONCRETE
 GRADE RINGS (2 MAX.)

ANCHOR BOLT
 (FOUR REQUIRED)

29"

2 (TWO) RINGS OF 3/4" WIDE
 CONSEAL CS-202 BUTYL RUBBER
 SEALANT CONTINUOUS ABOUT JOINT

MANHOLE STEPS
 12" C.C.

CONCRETE SHALL CONTAIN
 XYPEX CONCRETE ADMIXTURE
 WATERPROOFING

5" 48" DIA. 5"

FLEXIBLE NEOPRENE PIPE
 TO MANHOLE CONNECTOR
 (TYPICAL ALL OPENINGS)

SLOPE 1"/FT.

2" ABOVE PIPE ϕ

6"

4"

3" MIN. DEPTH OF
 POURED CONC. INV.

NOTES:

1. INCREASE MANHOLE DIA. TO 5'-0" FOR PIPE SIZES 30" DIA. & LARGER OR IF MANHOLE DEPTH EXCEEDS 16 FEET.
2. PRECAST CONCRETE MANHOLES TO CONFORM TO A.S.T.M. C-478.
3. MANHOLE STEPS SHALL BE STEEL, ENCASED IN POLYPROPYLENE PLASTIC, STEPS SHALL MEET REQUIREMENTS, ASTM D4101-82. THE STEEL SHALL BE A DEFORMED 1/2" DIA. REINFORCING ROD, GRADE 60 CONFORMING TO ASTM A-615.

**SANITARY SEWER
 48" PRECAST MANHOLE**

NIRA Consulting Engineers, Inc.

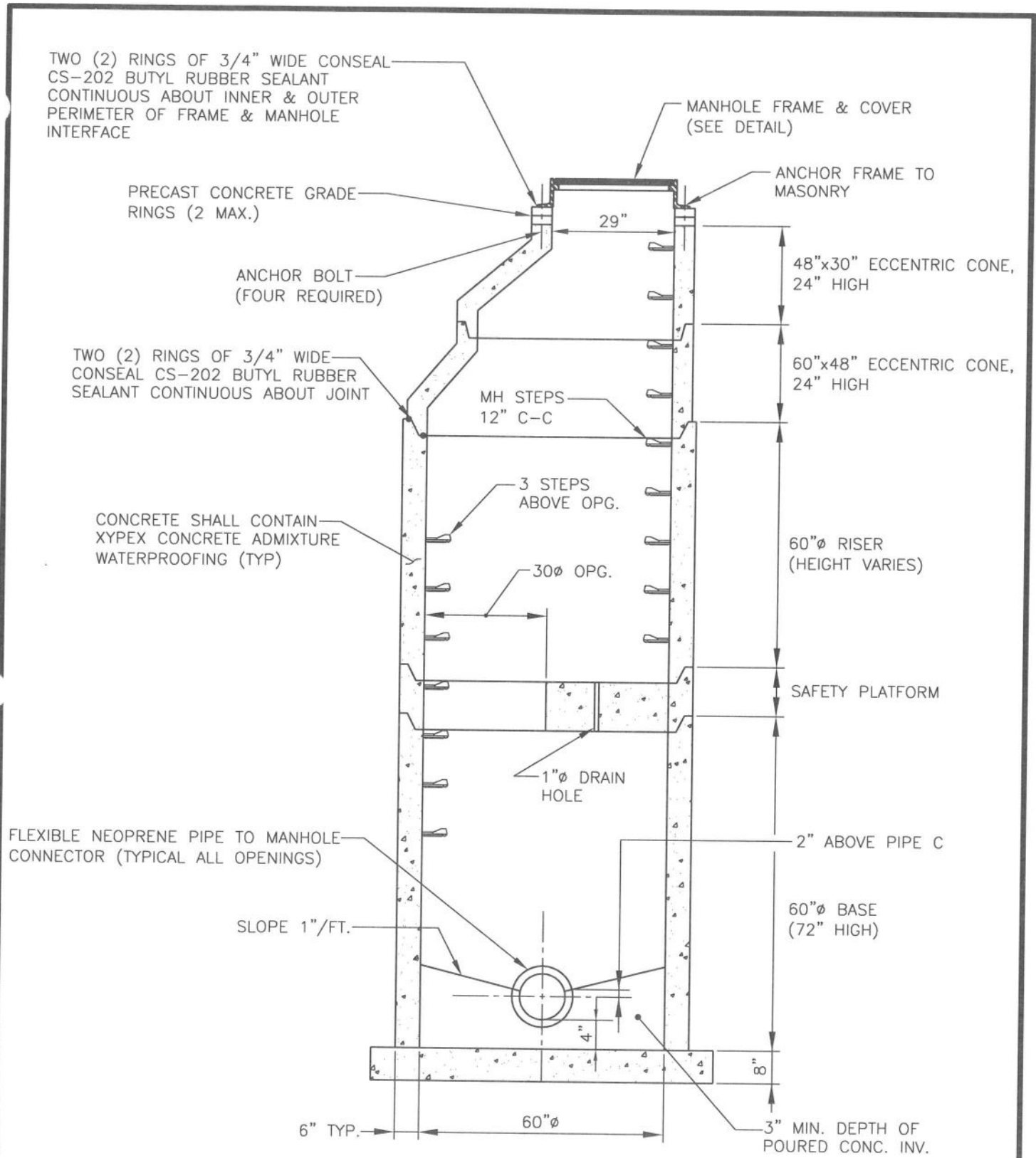

NOTES:

1. PRECAST CONCRETE MANHOLES TO CONFORM TO A.S.T.M. C-478.
2. MANHOLE STEPS SHALL BE STEEL, ENCASED IN POLYPROPYLENE PLASTIC, STEPS SHALL MEET REQUIREMENTS, ASTM D4101-82. THE STEEL SHALL BE A DEFORMED 1/2" DIA. REINFORCING ROD, GRADE 60 CONFORMING TO ASTM A-615.

**SANITARY SEWER
60" PRECAST MANHOLE**

NIRA Consulting Engineers, Inc.

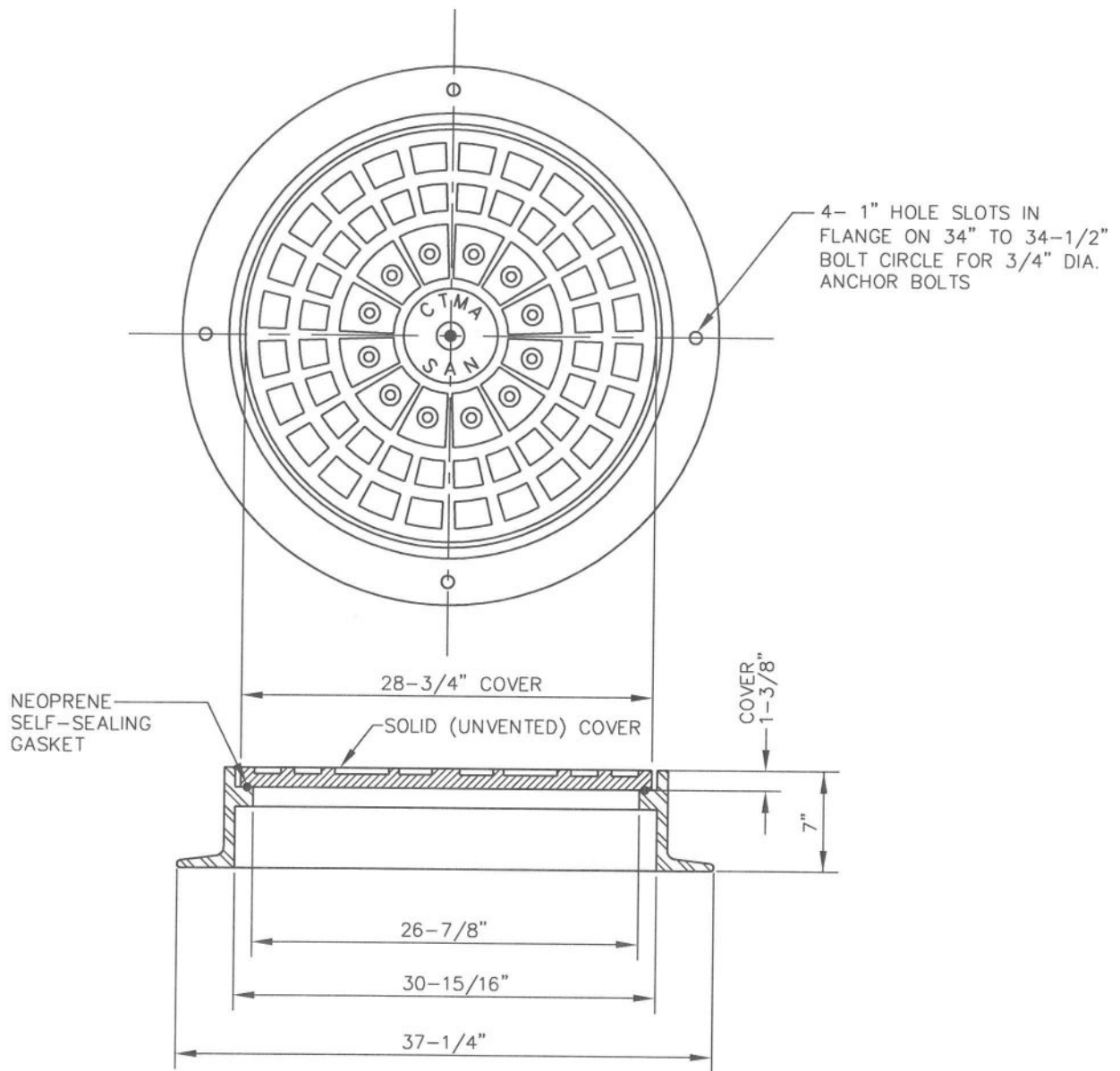

NOTES:

1. MANHOLE FRAME AND COVER SHALL BE EAST JORDAN IRON WORKS CATALOG NO. 1890, NEENAH FOUNDRY R-1753-A, SYRACUSE PATTERN NO. 1045 OR APPROVED EQUAL. LID SHALL HAVE SELF-SEALING GASKET.
2. COVER SHALL BE STAMPED AS SHOWN IN PLAN VIEW OR AS OTHERWISE NOTED.

STANDARD SANITARY SEWER
MANHOLE FRAME & COVER

NIRA Consulting Engineers, Inc.

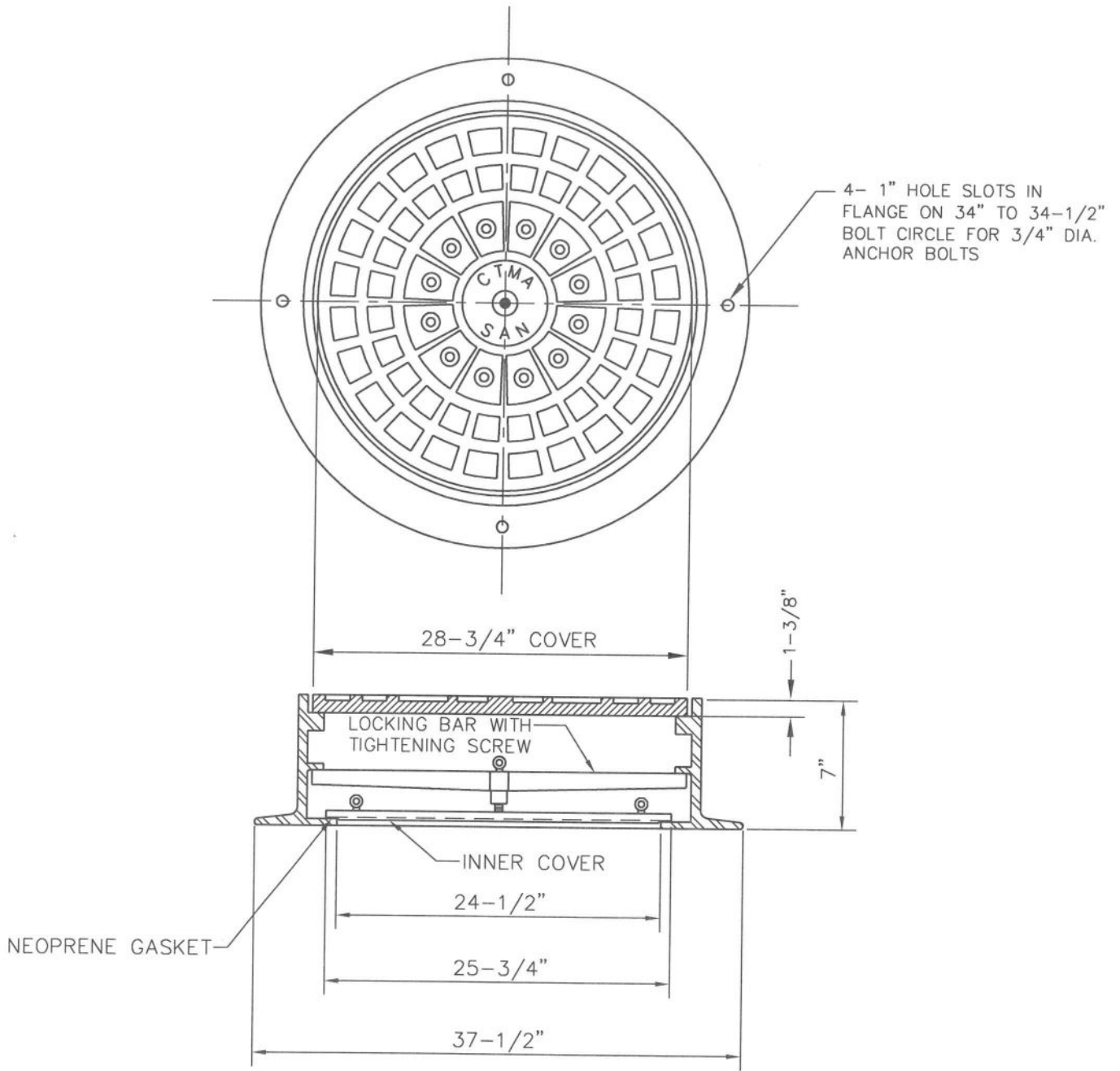

NOTES:

1. WATER-TIGHT FRAME AND COVER SHALL BE NEENAH FOUNDRY R-1755-F2, EAST JORDAN V-2150-3, SYRACUSE PATTERN NO. 6542, OR APPROVED EQUAL.
2. COVER SHALL BE STAMPED AS SHOWN IN PLAN VIEW OR AS OTHERWISE NOTED.

**WATER-TIGHT SANITARY SEWER
MANHOLE FRAME & COVER**

NIRA Consulting Engineers, Inc.

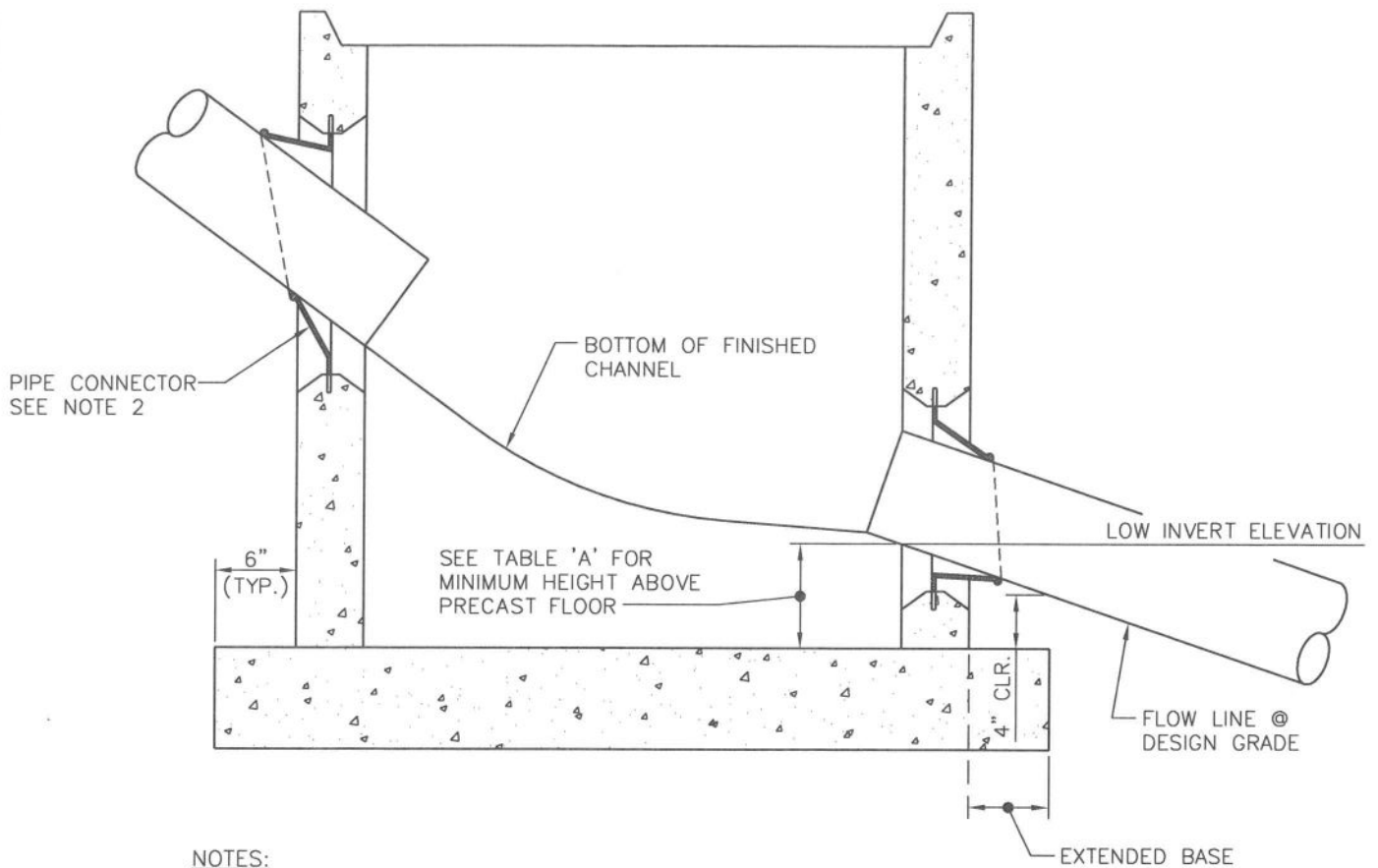

NOTES:

1. DURING MANUFACTURING, THE LOCATION OF THE LOW (OUTFALL) INVERT ELEVATION ON THE INSIDE OF THE MANHOLE WALL SHALL BE ADJUSTED RELATIVE TO THE PRECAST MANHOLE FLOOR TO ENSURE 4" CLEARANCE BETWEEN PIPE AND THE EXTENDED BASE OF THE MANHOLE AS SHOWN.
2. WHEN THE GRADE ENTERING OR EXITING THE MANHOLE IS 18% OR LESS, AN "A-LOK EXCEL CONNECTOR" (OR APPROVED EQUAL) IS REQUIRED, IF THE GRADE IS MORE THAN 18% A "Z-LOK CONNECTOR" (OR APPROVED EQUAL) IS REQUIRED.
3. CONCRETE CHANNEL BETWEEN PIPE INVERTS SHALL BE FORMED TO A SMOOTH PARABOLIC TRANSITION BETWEEN THE INVERT ELEVATIONS.

TABLE 'A'

DESIGN GRADE (%)	HEIGHT OF INVERT ABOVE FLOOR OF MANHOLE NEEDED TO PROVIDE 4" CLEARANCE FROM RIM OF BASE
0-10	5.5"
10-20	6.5"
20-30	7.5"
30-40	8.5"
40-50	9.5"
50-60	10.75"

**SANITARY SEWER
PRECAST CONCRETE MANHOLE
BASE DETAIL**

NIRA Consulting Engineers, Inc.

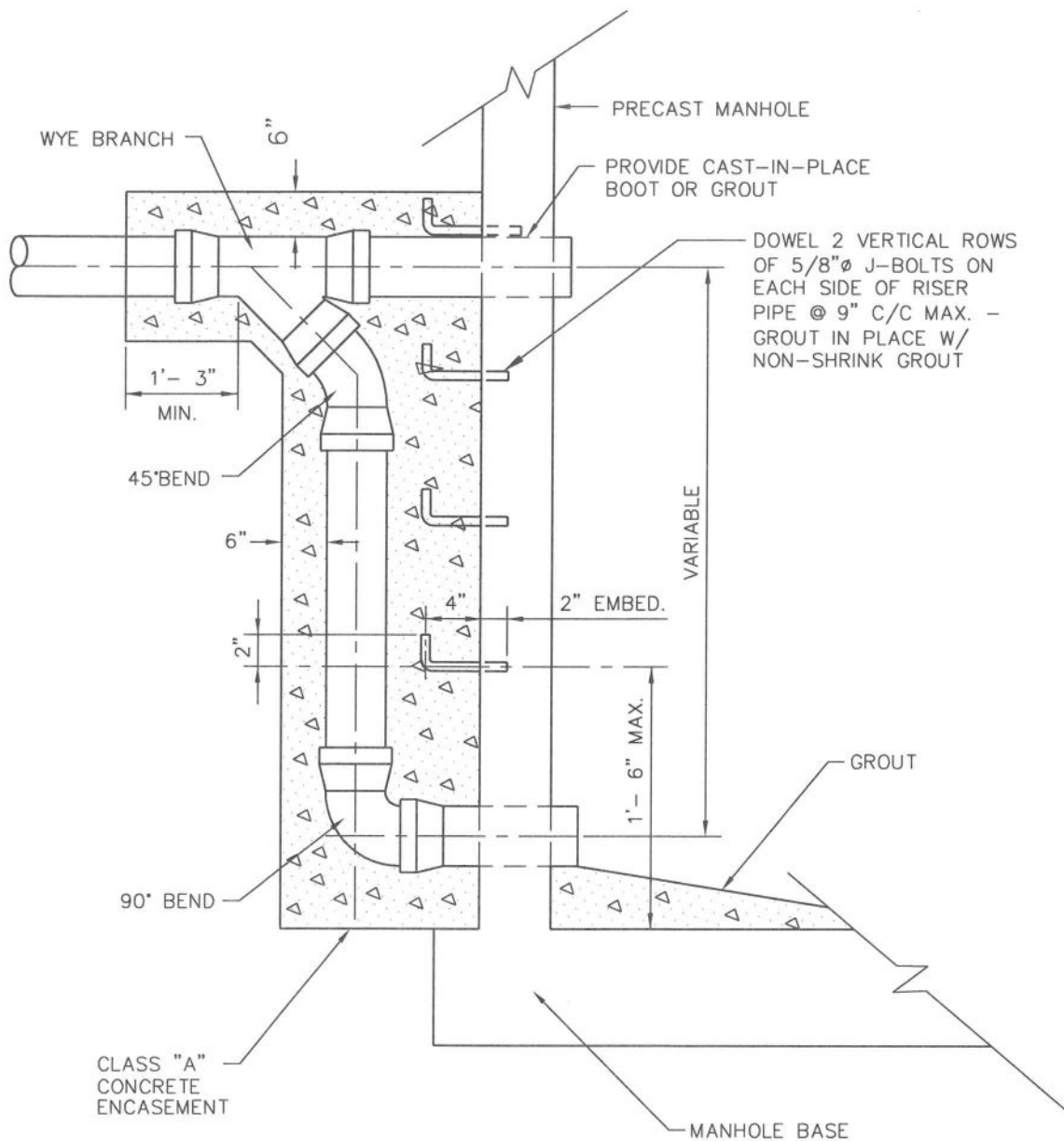

NOTE: PIPE MATERIAL & SIZE SHALL BE EQUAL TO THAT OF THE MAIN LINE SEWER.

**SANITARY SEWER
OUTSIDE DROP MANHOLE
CONNECTION DETAIL**

NIRA Consulting Engineers, Inc.

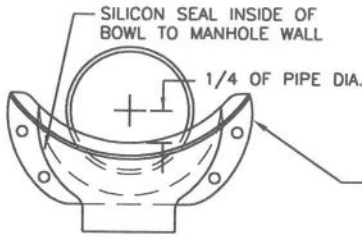

DROP BOWL MOUNTING POSITION

RELINER® INSIDE DROP BOWL SECURED WITH 4 STAINLESS STEEL BOLTS

RELINER® STAINLESS STEEL STRAPS OR EQUAL. SECURE TO STRUCTURE WITH 2 STAINLESS STEEL BOLTS. STRAP AT 4' INTERVALS (MIN. OF 2) SEE 7-3A

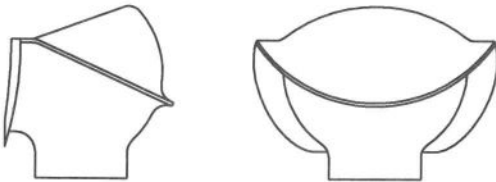

FORCE LINE HOOD

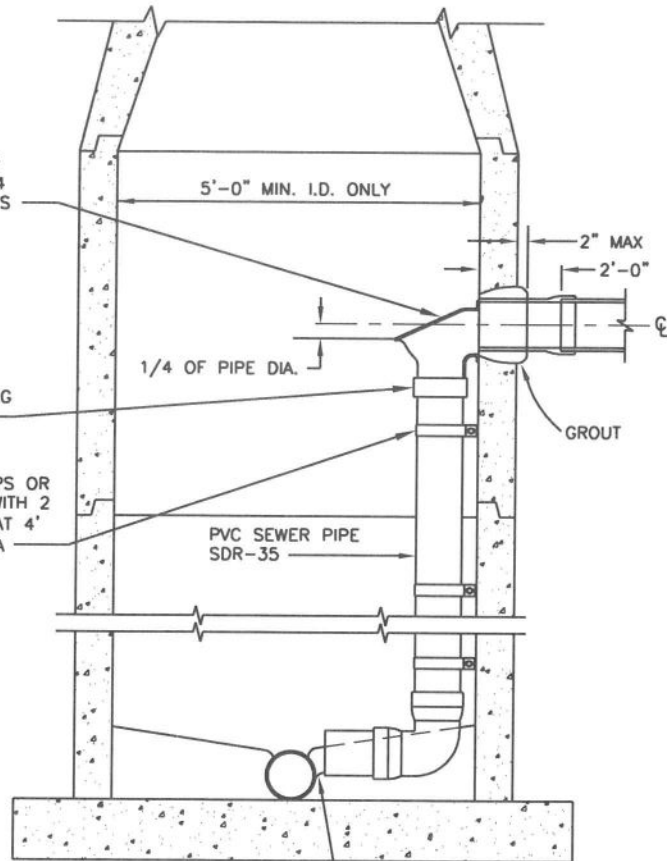

DROP CONNECTION PIPE INVERT SHALL MATCH THE SPRING-LINE OF THE EXIT PIPE.

INSIDE DROP CONNECTION (USE MUST BE APPROVED)

NOTES:

1. ALL INSIDE DROP CONNECTIONS FOR SERVICES AND COLLECTOR SEWERS SHALL USE THE DROP BOWL AS PRODUCED BY: RELINER-DURAN, INC. 53 MT. ARCHER RD, LYME, CT 06371 (860)434-0277 FAX: (860)434-3195 OR EQUAL.
2. DROP BOWL MODEL "A-4" SHALL BE USED FOR ALL LINES UP THROUGH FULL 6" INLETS. DROP BOWL MODEL "A-6" SHALL BE USED FOR ALL 8" INLETS. DROP BOWLS MODEL "B-8" SHALL BE USED FOR ALL 10" INLETS. LINES LARGER THAN 10 SHALL BE AS DIRECTED BY THE DIRECTOR.
3. THE FORCE LINE HOOD SHALL BE ATTACHED ON MODELS "A-4" & "A-6" WHEN THE INCOMING LINE IS FROM A FORCE MAIN OR THE SLOPE IS S=0.03 OR GREATER.

SECURE DROP PIPE TO MANHOLE WALL WITH RELINER-DURAN, INC STAINLESS STEEL ADJUSTABLE CLAMPING BRACKETS OR EQUAL (SEE DETAIL 7-3A).

ATTACH THE DROP BOWL & EACH CLAMPING BRACKET TO THE MANHOLE WALL WITH 3/8" X 3 3/4" RAMSET/RED HEAD BOLTS HELD INPLACE WITH 2 STAGE EPOXY PASTE. EPOXY SHALL MEET THE FOLLOWING REQUIREMENTS:

EPOXY PASTE SHALL BE A TWO COMPONENT, 100% SOLID SYSTEM. EPOXY SHALL BE SIKADUR 31 HI-MOD GEL BY SIKA CORPORATION (PHONE 592/941-0231) OR EQUAL.

THE EPOXY PASTE SHALL DEVELOP A MINIMUM COMPRESSIVE STRENGTH OF 5,000 PSI IN 28 DAYS WHEN TESTED IN ACCORDANCE WITH ASTM D695 AT 73 DEGREES.

THE EPOXY PASTE SHALL DEVELOP A MINIMUM TENSILE STRENGTH OF 3,000 PSI IN 14 DAYS WHEN TESTED IN ACCORDANCE WITH ASTM D638.

THE EPOXY PASTE SHALL DEVELOP A MINIMUM BOND STRENGTH OF 2,000 PSI IN 2 DAYS WHEN TESTED IN ACCORDANCE WITH ASTM C882 (HARDENED CONCRETE TO HARDENED CONCRETE).

MANUFACTURER'S INSTRUCTIONS SHALL BE PRINTED ON EACH CONTAINER IN WHICH THE MATERIALS ARE PACKAGED.

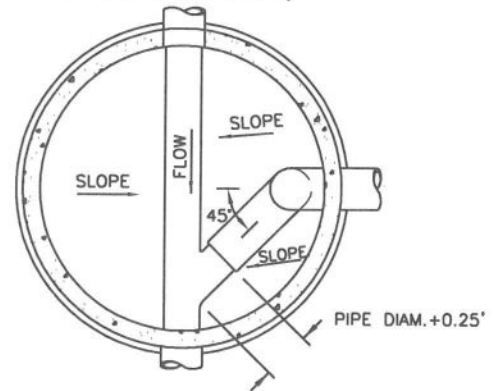

INSIDE DROP - PLAN

SANITARY SEWER INSIDE DROP MANHOLE CONNECTION DETAIL

NIRA Consulting Engineers, Inc.

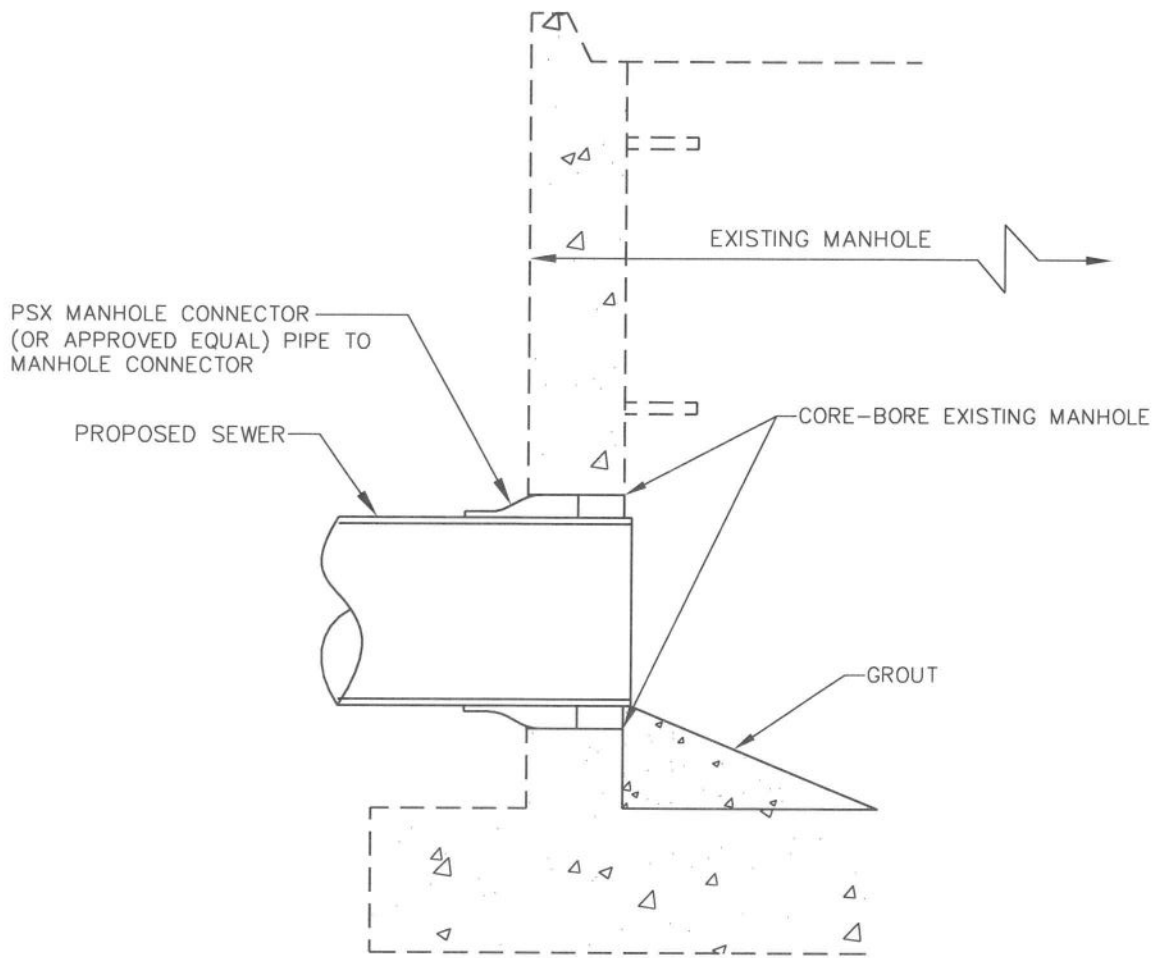

CONNECTION TO EXISTING
SANITARY SEWER
PRECAST MANHOLE

NIRA Consulting Engineers, Inc.

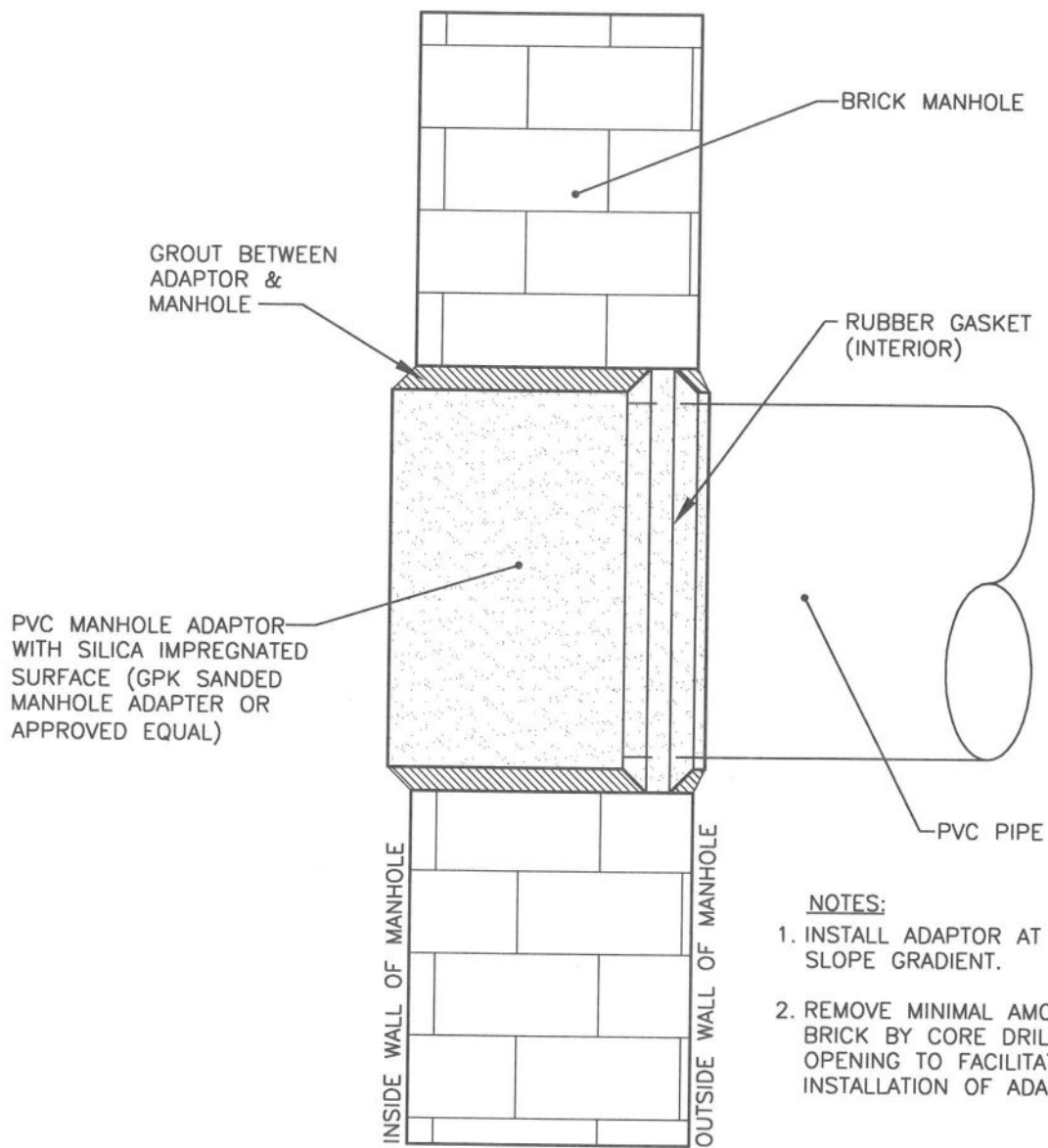

CONNECTION TO EXISTING
SANITARY SEWER
BRICK MANHOLE

NIRA Consulting Engineers, Inc.

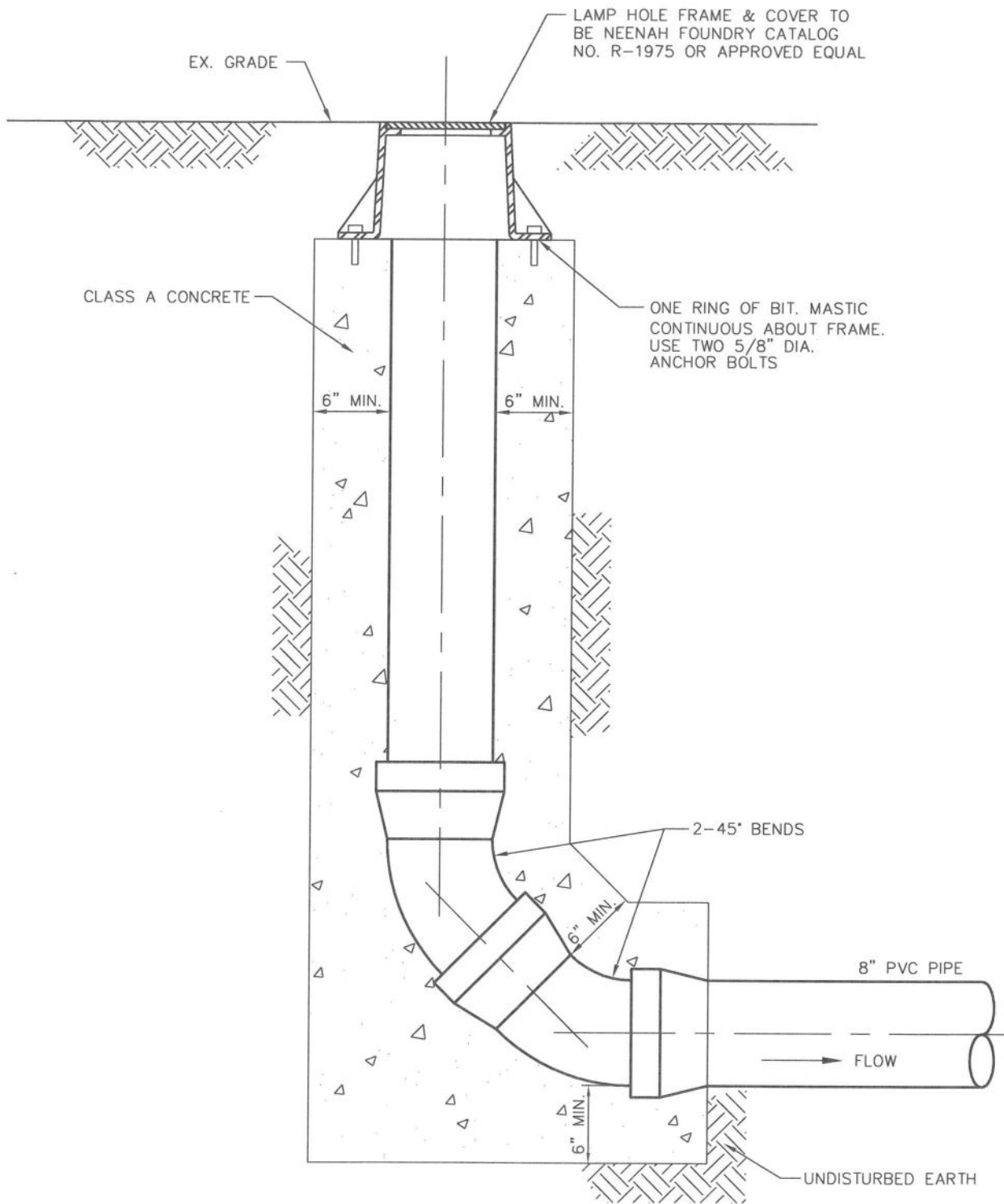

NOTE

1. ALL MATERIAL TO BE SAME AS SEWER MAIN.
2. FRAME AND COVER SHALL BE CAST IRON, ASTM A48, CLASS 30.
3. PIPE SIZE SHALL BE SAME AS SEWER MAIN.

**SANITARY SEWER
LAMPHOLE DETAIL**

NIRA Consulting Engineers, Inc.

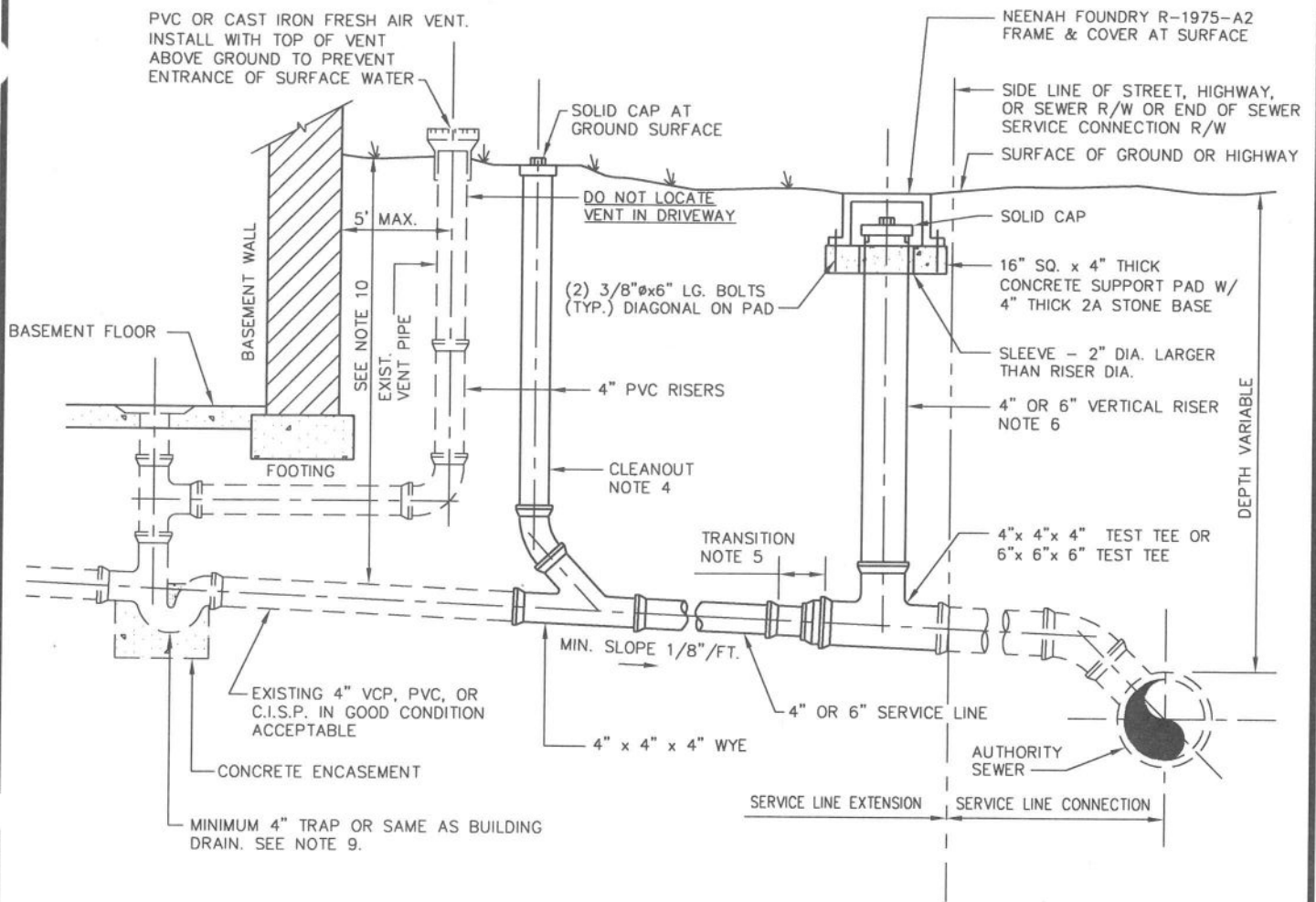

NOTES:

1. THE ENTIRE INSTALLATION MUST BE INSPECTED AND APPROVED BY THE AUTHORITY AND THE ALLEGHENY COUNTY HEALTH DEPT.
2. ALL MATERIALS MUST BE INSTALLED IN ACCORDANCE WITH THE ALLEGHENY COUNTY PLUMBING CODE, AND IN ACCORDANCE WITH THE AUTHORITY RULES AND REGULATIONS.
3. BEFORE WORK IS STARTED A PLAN MUST BE FILED WITH THE ALLEGHENY COUNTY HEALTH DEPARTMENT PLUMBING DIVISION AND AN APPLICATION MUST BE FILED WITH THE AUTHORITY.
4. CLEANOUTS SHALL BE INSTALLED AT 50' MAXIMUM INTERVALS FOR 4" PIPE OR 100' MAXIMUM INTERVALS FOR 6" PIPE, AND AT CHANGES IN DIRECTION GREATER THAN 45', AND WHEN DEPTH EXCEEDS 4'.
5. TRANSITION BETWEEN 6" PIPE TO 4" PIPE MUST BE MADE IN 18".
6. VERTICAL RISER INSTALLED AS REQUIRED BY THE AUTHORITY RULES AND REGULATIONS.
7. ALL PIPING & FITTINGS SHALL BE: PVC SDR 35; PVC SCH. 40; ABS SCH. 40; CAST IRON EXTRA HEAVY & SERVICE WEIGHT; OR APPROVED EQUAL.
8. ANY LINES INSTALLED IMPROPERLY OR COVERED WITHOUT INSPECTION MUST BE REMOVED OR UNCOVERED AT THE PROPERTY OWNER'S EXPENSE.
9. ALL COMMERCIAL BUILDINGS SHALL BE MINIMUM 6" PIPE OR LARGER. ALL RESIDENTIAL BUILDINGS HAVE OPTION TO INSTALL 4" OR 6" PIPE.
10. THIS DETAIL IS APPLICABLE TO NEW BUILDING CONSTRUCTION WHERE THE LATERAL IS GREATER THAN 6' DEPTH & CONNECTIONS TO ALL EXISTING BUILDINGS. A MINIMUM 3 FEET OF COVER OVER LATERAL IS REQUIRED.

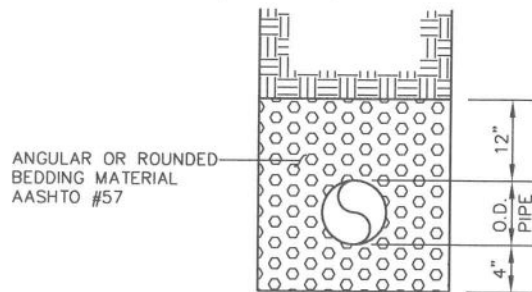

TRENCH SECTION

**SANITARY SEWER
LATERAL INSTALLATION
(INTERIOR TRAP)**

NIRA Consulting Engineers, Inc.

PVC OR CAST IRON FRESH AIR VENT.
INSTALL WITH TOP OF VENT
ABOVE GROUND TO PREVENT
ENTRANCE OF SURFACE WATER

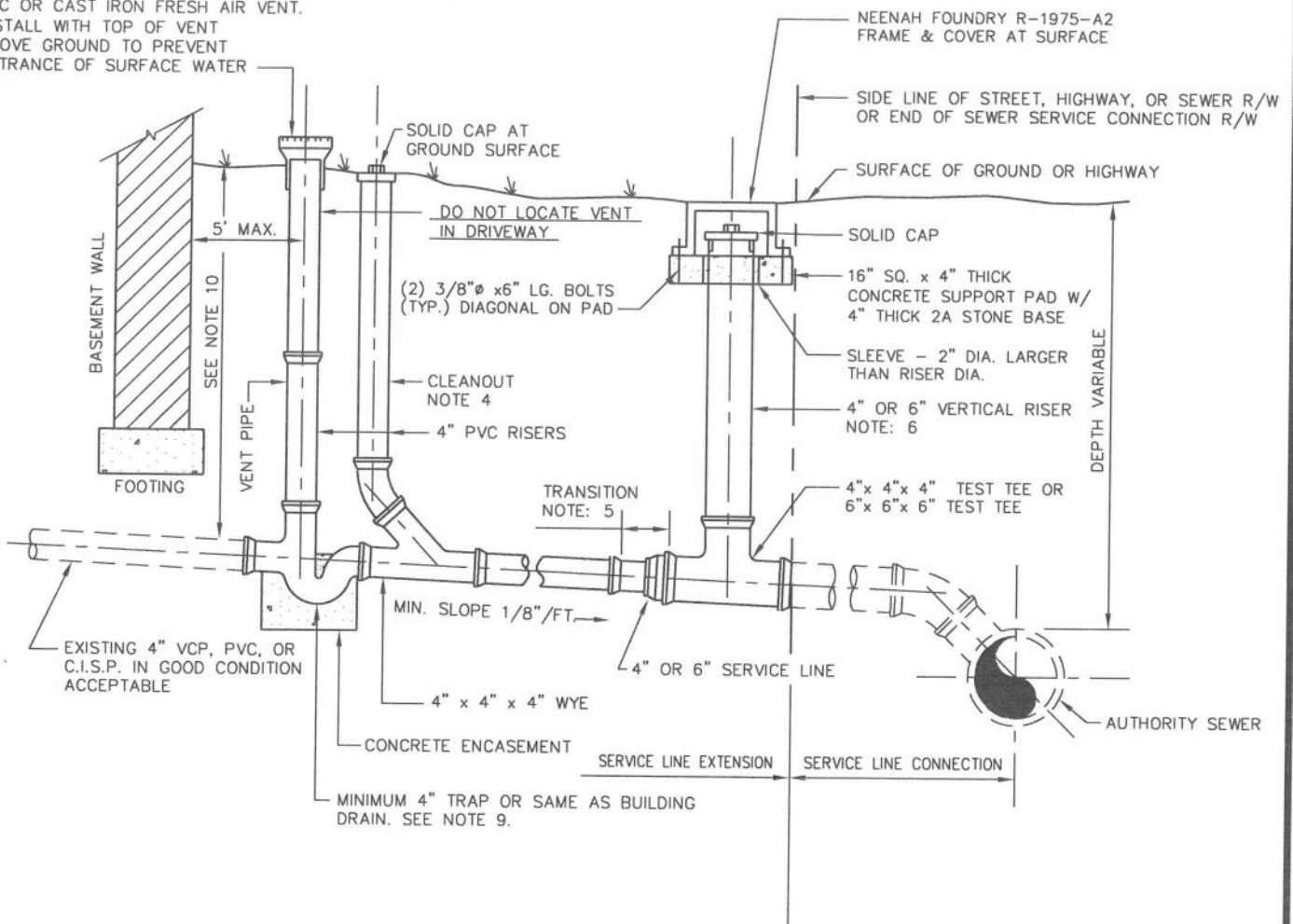

NOTES:

1. THE ENTIRE INSTALLATION MUST BE INSPECTED AND APPROVED BY THE AUTHORITY AND THE ALLEGHENY COUNTY HEALTH DEPT.
2. ALL MATERIALS MUST BE INSTALLED IN ACCORDANCE WITH THE ALLEGHENY COUNTY PLUMBING CODE, AND IN ACCORDANCE WITH THE AUTHORITY RULES AND REGULATIONS.
3. BEFORE WORK IS STARTED A PLAN MUST BE FILED WITH THE ALLEGHENY COUNTY HEALTH DEPARTMENT PLUMBING DIVISION AND AN APPLICATION MUST BE FILED WITH THE AUTHORITY.
4. CLEANOUTS SHALL BE INSTALLED AT 50' MAXIMUM INTERVALS FOR 4" PIPE OR 100' MAXIMUM INTERVALS FOR 6" PIPE, AND AT CHANGES IN DIRECTION GREATER THAN 45°, AND WHEN DEPTH EXCEEDS 4'.
5. TRANSITION BETWEEN 6" PIPE TO 4" PIPE MUST BE MADE IN 18".
6. VERTICAL RISER INSTALLED AS REQUIRED BY THE AUTHORITY RULES AND REGULATIONS.
7. ALL PIPING & FITTINGS SHALL BE: PVC SDR 35; PVC SCH. 40; ABS SCH. 40; CAST IRON EXTRA HEAVY & SERVICE WEIGHT; OR APPROVED EQUAL.
8. ANY LINES INSTALLED IMPROPERLY OR COVERED WITHOUT INSPECTION MUST BE REMOVED OR UNCOVERED AT THE PROPERTY OWNER'S EXPENSE.
9. ALL COMMERCIAL BUILDINGS SHALL BE MINIMUM 6" PIPE OR LARGER. ALL RESIDENTIAL BUILDINGS HAVE OPTION TO INSTALL 4" OR 6" PIPE.
10. THIS DETAIL IS APPLICABLE TO NEW BUILDING CONSTRUCTION WHERE THE LATERAL IS GREATER THAN 6' DEPTH & CONNECTIONS TO ALL EXISTING BUILDINGS. A MINIMUM 3 FEET OF COVER OVER LATERAL IS REQUIRED.

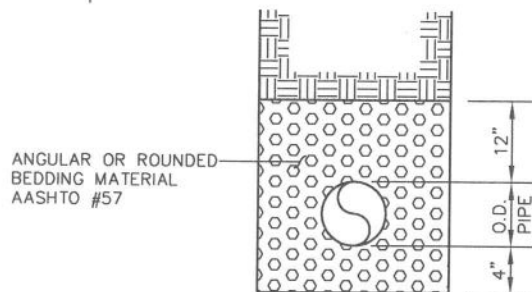

TRENCH SECTION

**SANITARY SEWER
LATERAL INSTALLATION
(EXTERIOR TRAP)**

NIRA Consulting Engineers, Inc.

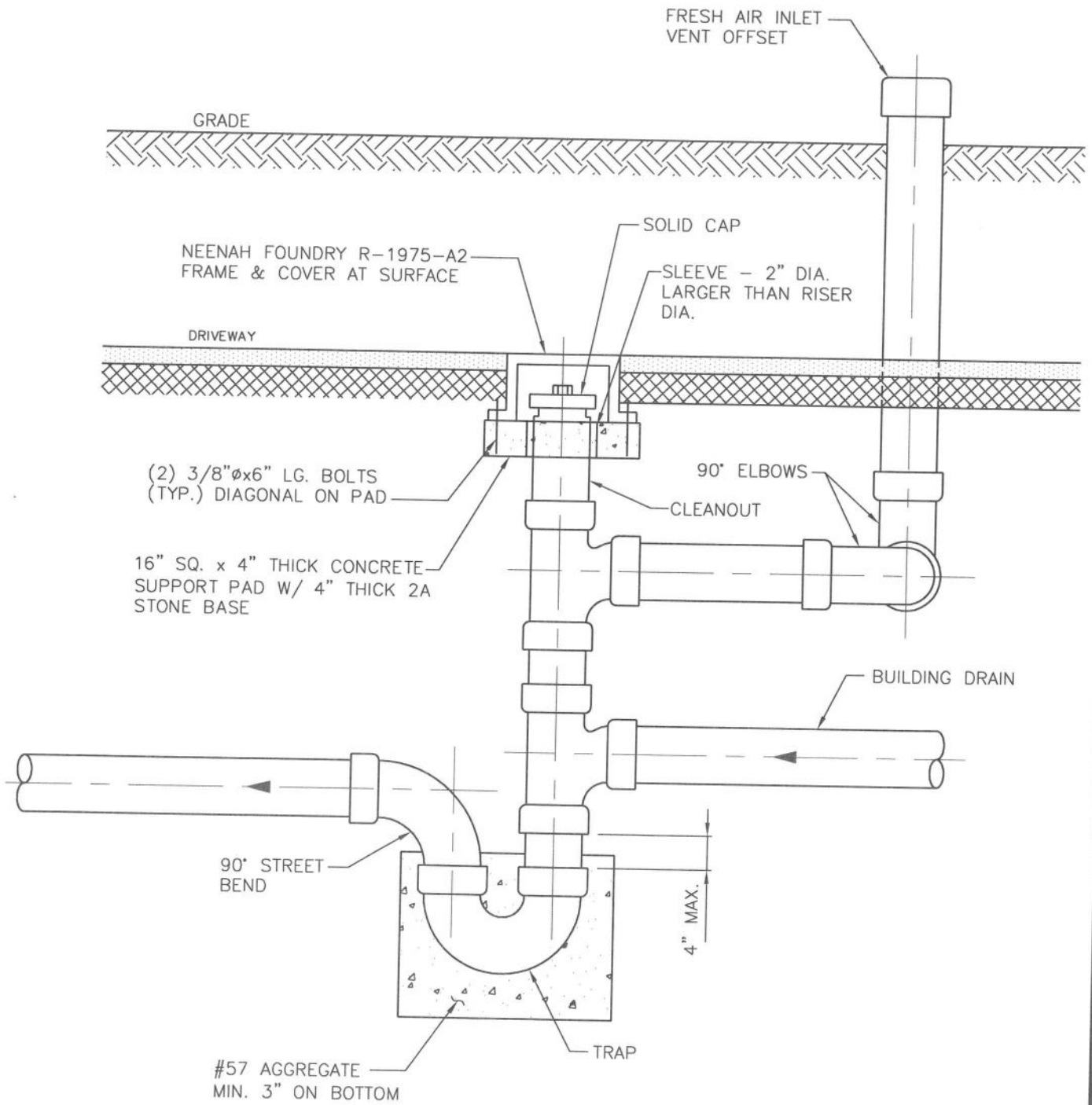

**SANITARY SEWER LATERAL
FRESH AIR VENT ON ELEVATED
GRADES AT DRIVEWAYS**

NIRA Consulting Engineers, Inc.

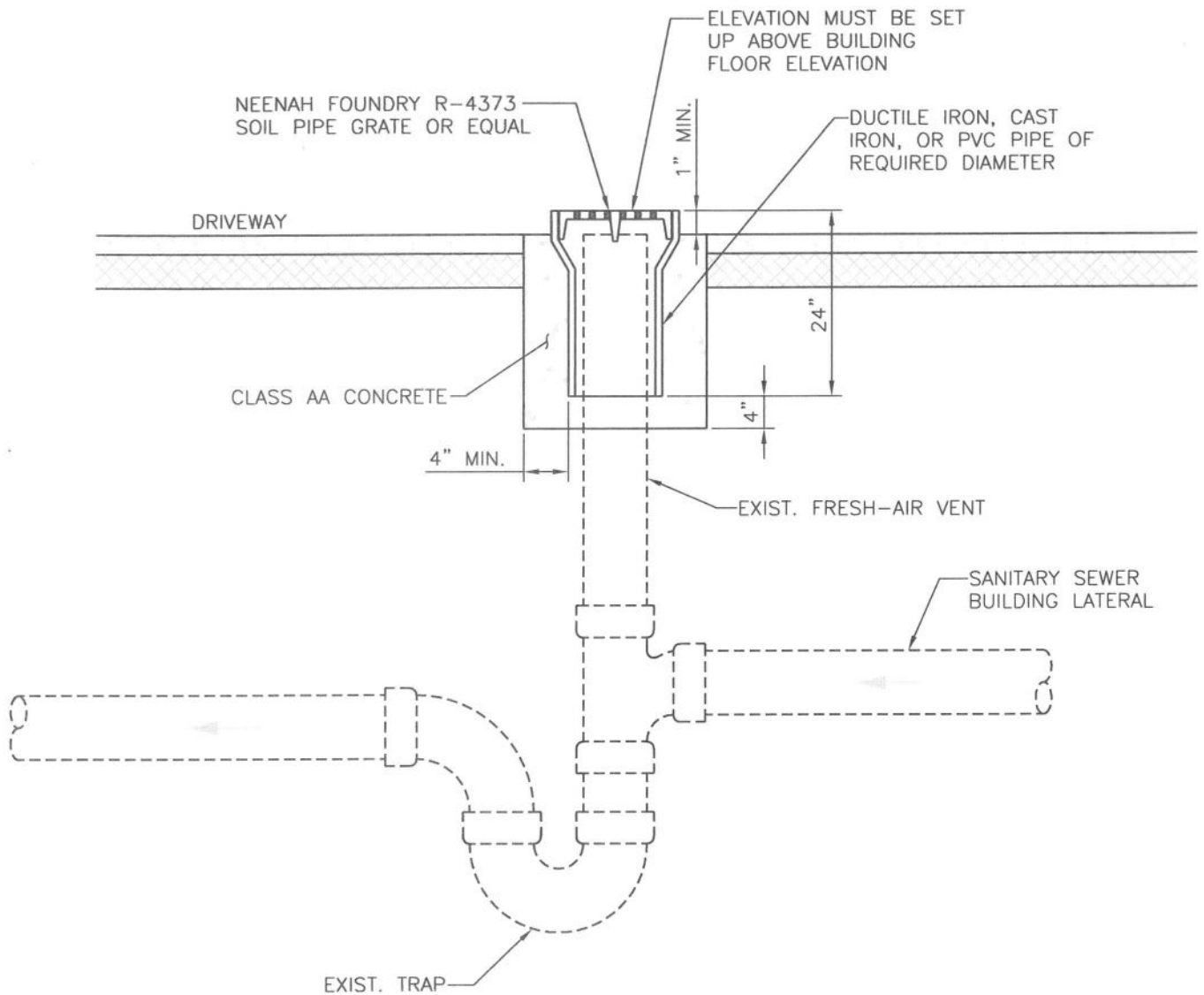

NOTES:

1. THIS METHOD MAY ONLY BE USED WHEN THE FRESH-AIR VENT IS LOCATED IN SUCH AN AREA THAT WILL NOT BE SUBJECT TO VEHICULAR TRAFFIC, AND THE FRESH-AIR VENT IS NOT USED AS THE PRIMARY DRIVEWAY DRAIN.
2. CONSIDERATION SHOULD BE GIVEN TO PEDESTRIAN TRAFFIC. THIS MAY NOT BE A DESIRED METHOD IF IT CREATES A SIGNIFICANT TRIPPING HAZARD.
3. IF THE FRESH-AIR VENT IS USED AS THE PRIMARY DRIVEWAY DRAIN, THEN A SEPARATE STORM DRAIN MUST BE INSTALLED AND ROUTED EITHER BY PUMP OR BY GRAVITY TO THE GROUND SURFACE OR OTHER STORM DRAINS.

**SANITARY SEWER LATERAL
FRESH AIR VENT IN DRIVEWAY**

NIRA Consulting Engineers, Inc.

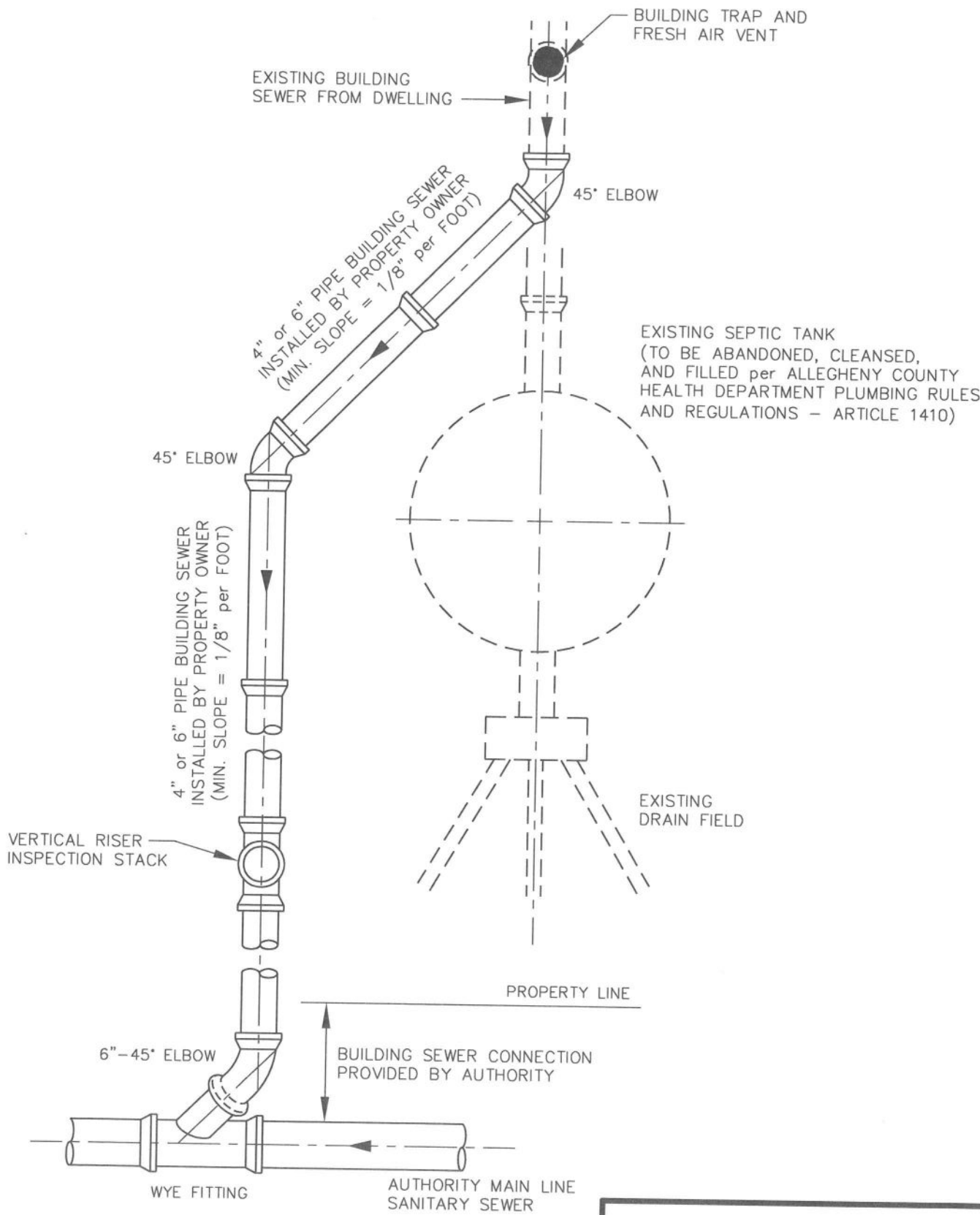

**SANITARY LATERAL
DISCONNECT FROM SEPTIC
SYSTEM**

NIRA Consulting Engineers, Inc.

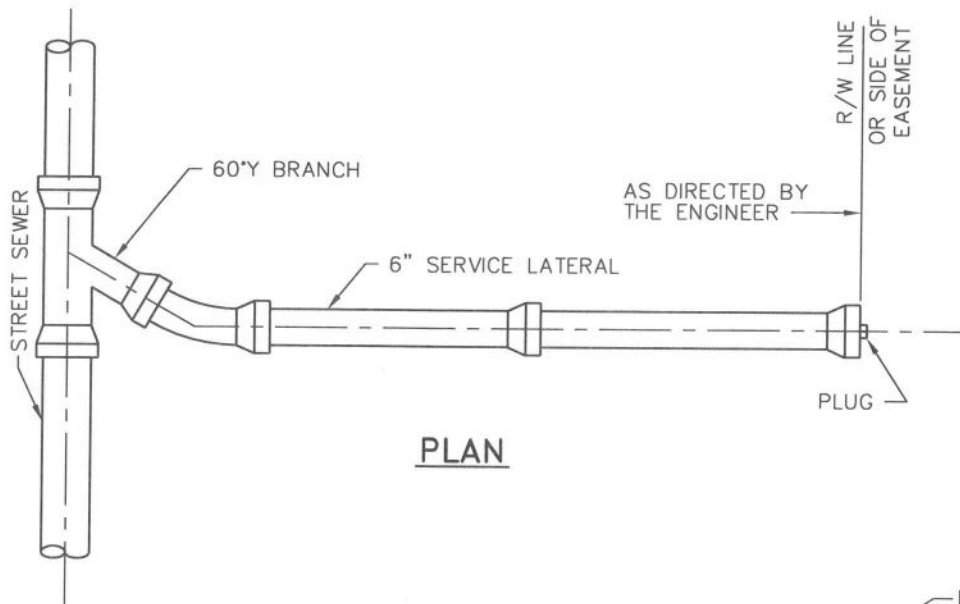

PLAN

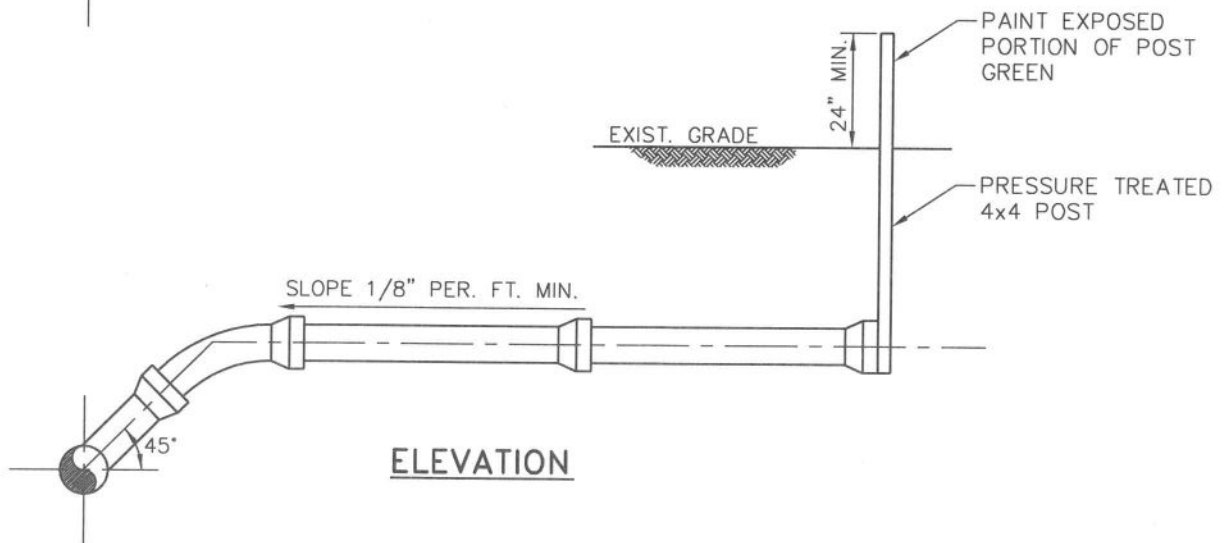

ELEVATION

STANDARD 6" SANITARY SEWER
SERVICE CONNECTION

NIRA Consulting Engineers, Inc.

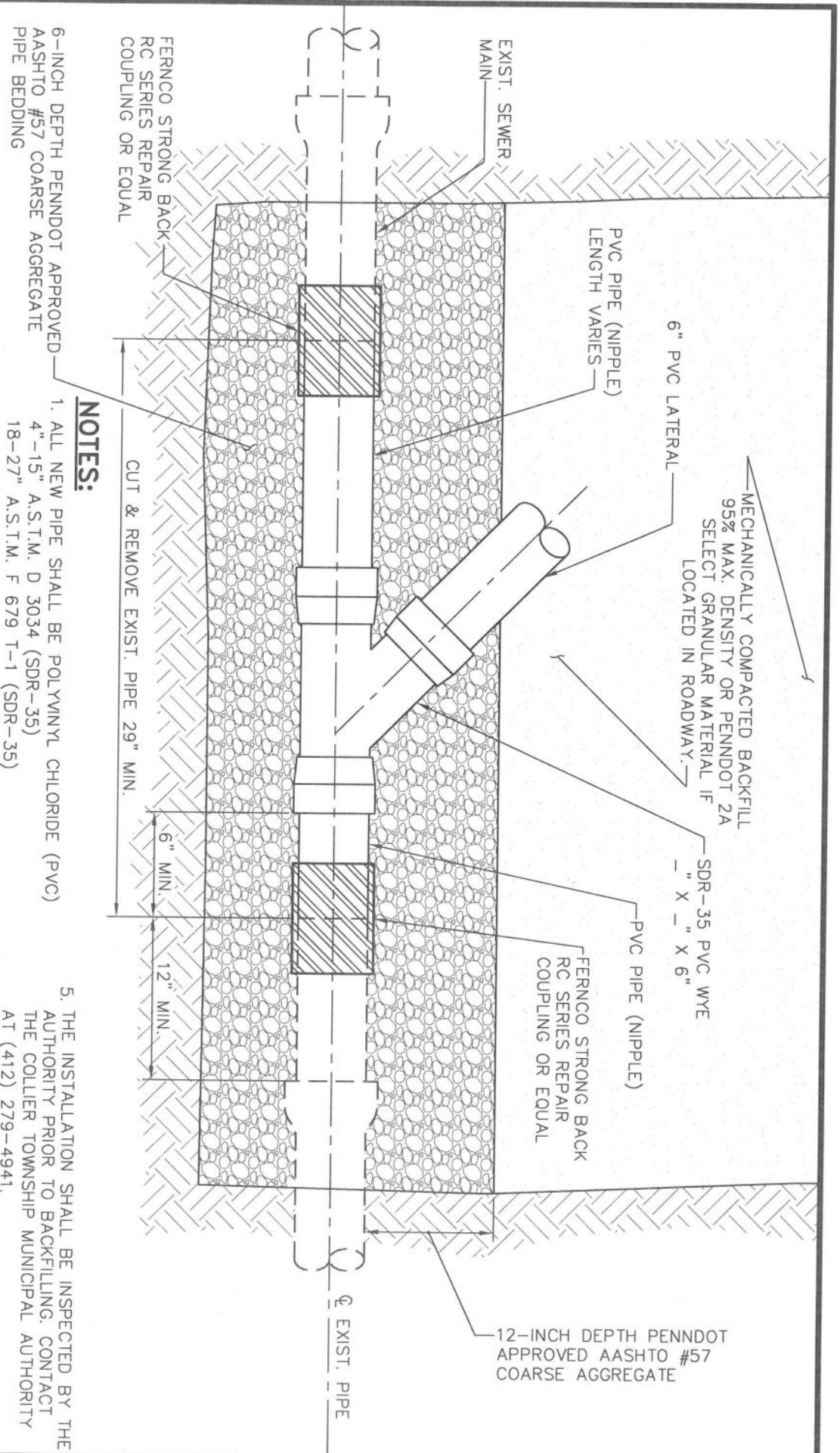

MECHANICALLY COMPACTED BACKFILL
95% MAX. DENSITY OR PENNDOT 2A
SELECT GRANULAR MATERIAL IF
LOCATED IN ROADWAY.

SDR-35 PVC WYE
" X " X 6"

PVC PIPE (NIPPLE)

FERNCO STRONG BACK
RC SERIES REPAIR
COUPLING OR EQUAL

12-INCH DEPTH PENNDOT
APPROVED AASHTO #57
COARSE AGGREGATE

FERNCO STRONG BACK
RC SERIES REPAIR
COUPLING OR EQUAL

CUT & REMOVE EXIST. PIPE 29" MIN.

6" MIN. 12" MIN.

6-INCH DEPTH PENNDOT APPROVED
AASHTO #57 COARSE AGGREGATE
PIPE BEDDING

NOTES:

1. ALL NEW PIPE SHALL BE POLYVINYL CHLORIDE (PVC)
4"-15" A.S.T.M. D 3034 (SDR-35)
18-27" A.S.T.M. F 679 T-1 (SDR-35)
2. THE PROPOSED WYE IS SHOWN AT 90° FROM HORIZONTAL
(12 O'CLOCK) FOR ILLUSTRATION PURPOSES ONLY. IT IS
DESIRABLE TO HAVE THE NEW WYE INSTALLED AT 45° FROM
HORIZONTAL. REFER TO THE "LATERAL INSTALLATION DETAIL".
3. THE PROPERTY OWNER IS RESPONSIBLE FOR SECURING ALL
NECESSARY PERMITS INCLUDING STREET OPENING AND
COMPLETING ALL REQUIRED RESTORATION WORK.
4. THE PROPERTY OWNER SHALL PERFORM ALL REQUIRED
EXCAVATION, SUPPLY ALL REQUIRED MATERIALS, AND NOTIFY
OTHER UTILITY COMPANIES IN ACCORDANCE WITH PA. ACT 172.
5. THE INSTALLATION SHALL BE INSPECTED BY THE
AUTHORITY PRIOR TO BACKFILLING. CONTACT
THE COLLIER TOWNSHIP MUNICIPAL AUTHORITY
AT (412) 279-4941.
6. PVC SLIP COUPLINGS MAY BE USED INLEU OF
FERNCO STRONG BACK COUPLINGS WHEN THE
EXISTING SEWER MAIN IS PVC.

**TYPICAL NEW SERVICE
WYE/LATERAL CONNECTION TO
EXISTING SEWER MAIN**

NIRA Consulting Engineers, Inc.

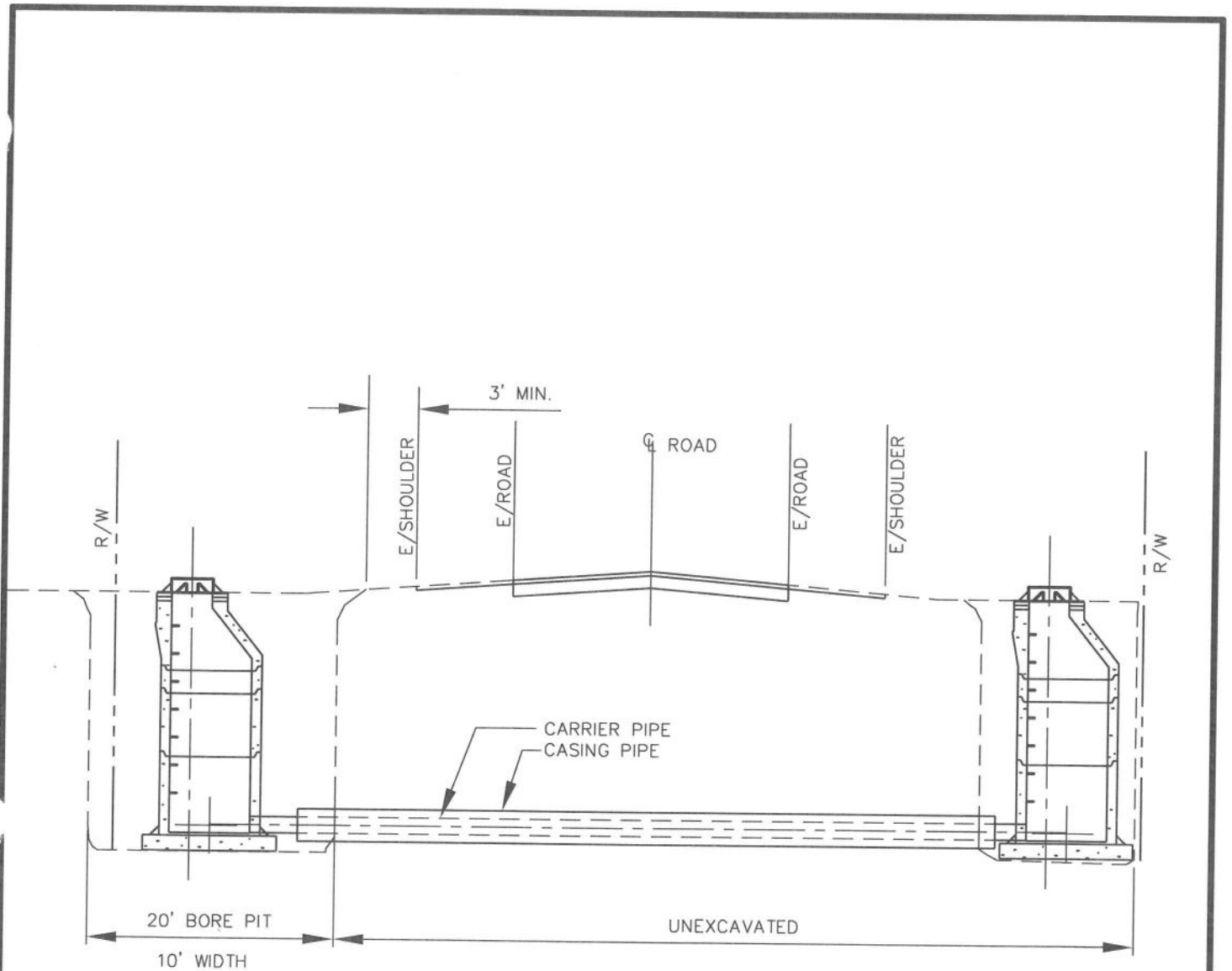

SANITARY SEWER
 TYPICAL BORE DETAIL

NIRA Consulting Engineers, Inc.

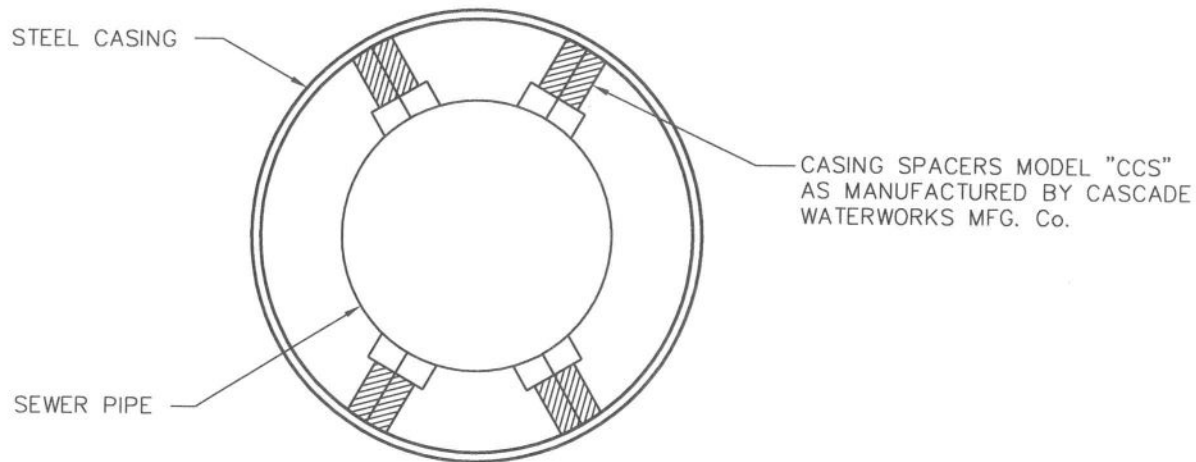

SEWER SIZE	6"	8"	10"	12"	15"	18"	21"	24"	27"	30"	42"
CASING SIZE	12"	14"	16"	20"	24"	30"	30"	36"	38"	42"	52"

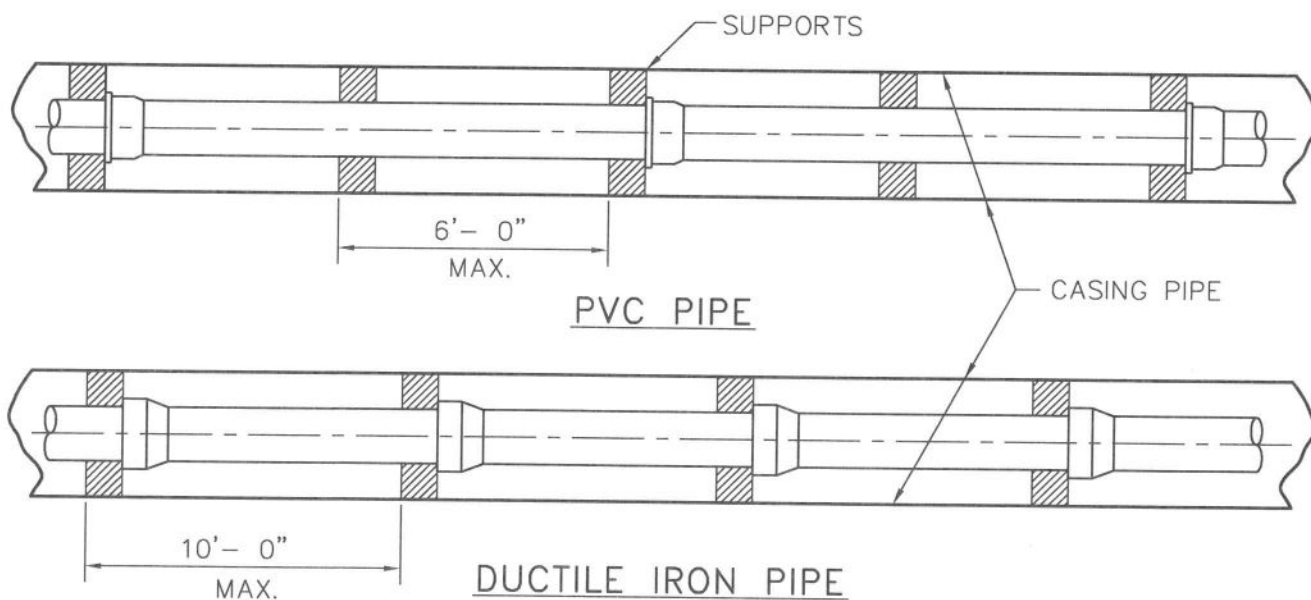

NOTE:
 BOTH ENDS OF CASING SHALL BE CAPPED
 WITH CASCADE MODEL "CCES" END SEALS

**SANITARY SEWER
 CASING & SUPPORT DETAILS
 FOR BORING**

NIRA Consulting Engineers, Inc.

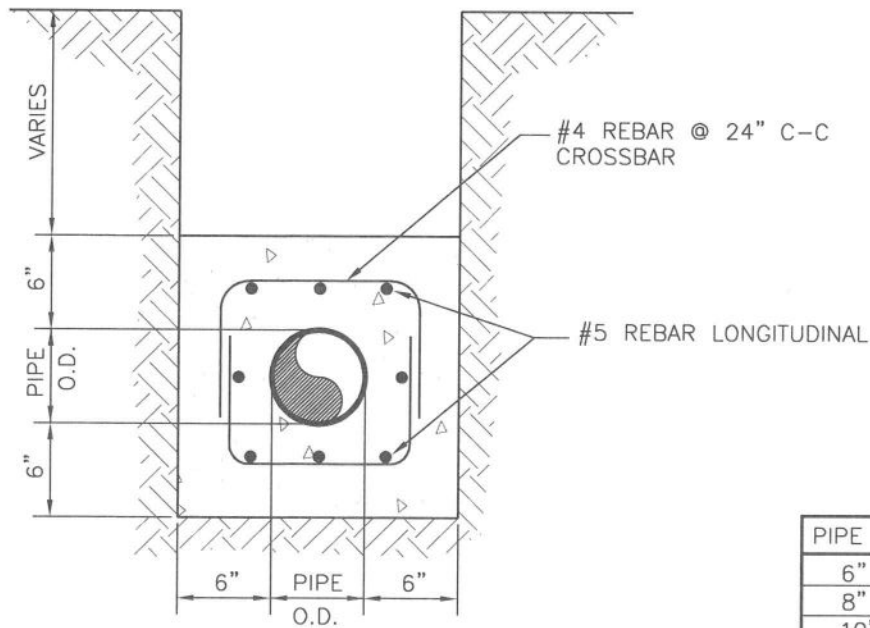
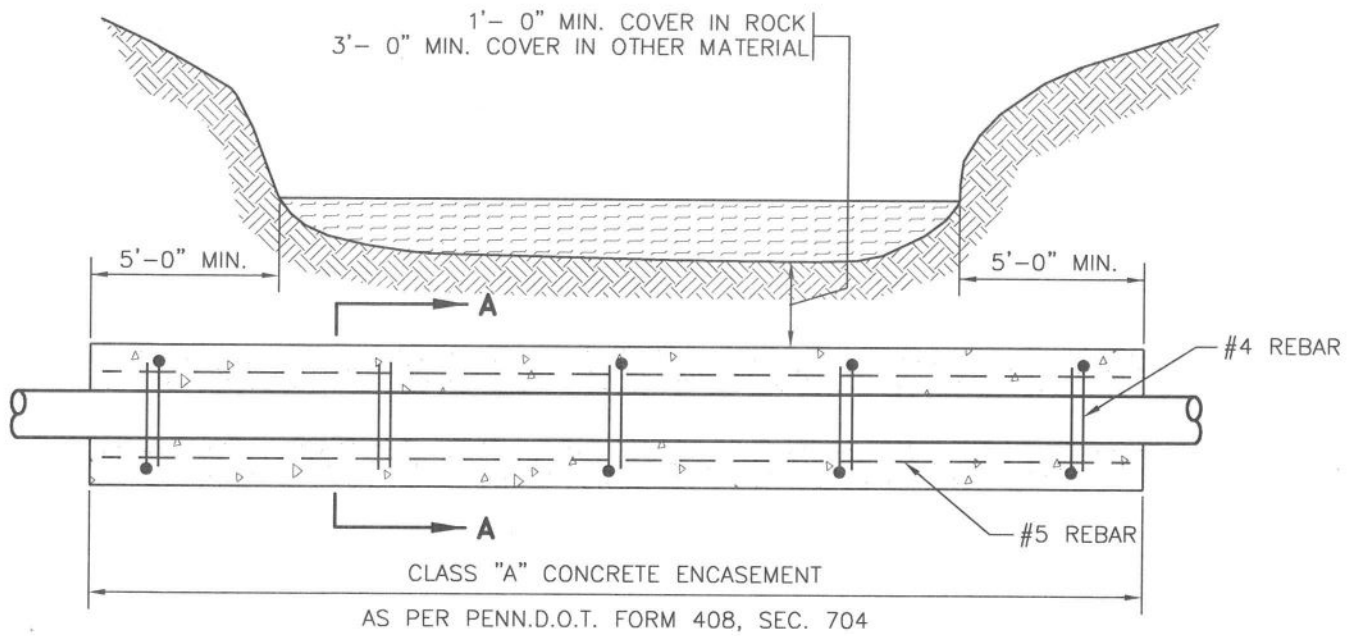

SECTION A-A

PIPE SIZE	QUANTITY (C.F. PER L.F.)
6"	2.1
8"	2.5
10"	2.9
12"	3.3
15"	3.8
18"	4.6
21"	5.4

**SANITARY SEWER
CONCRETE ENCASEMENT DETAIL**

NIRA Consulting Engineers, Inc.

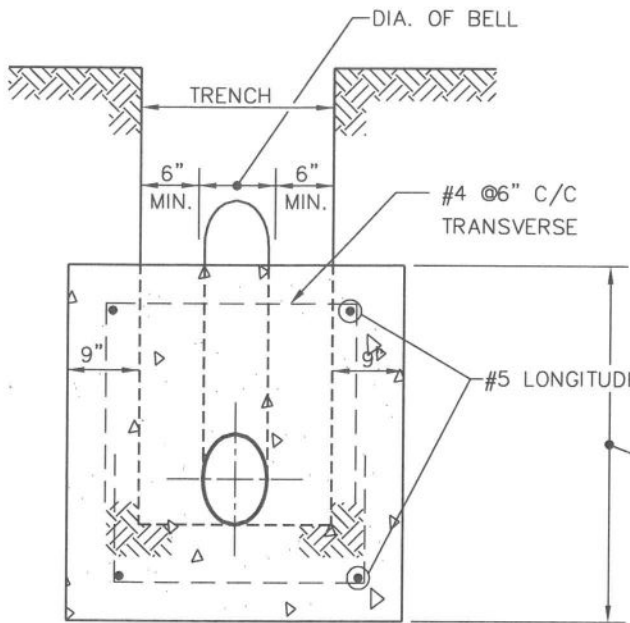

END VIEW

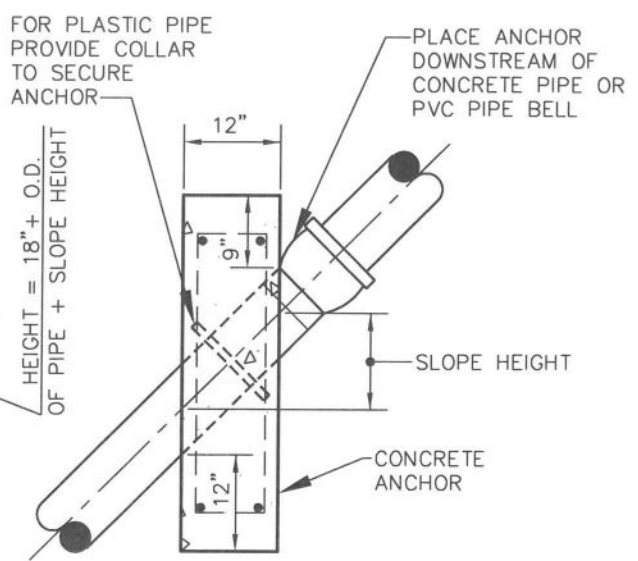

SIDE VIEW

NOTES:

1. ANCHORS TO BE SPACED AS SPECIFIED.
2. ALL CONCRETE TO BE CLASS "A" IF CONCRETE IS NOT FORMED, CONCRETE DIMENSIONS SHALL BE MINIMUM.

PIPE ANCHOR SPACING	
SLOPE	C-C SPACING
20% - 35%	36' - 0" MAX.
35% - 50%	24' - 0" MAX.
50% - >	16' - 0" MAX.

**SANITARY SEWER
CONCRETE PIPE ANCHOR
DETAIL**

NIRA Consulting Engineers, Inc.

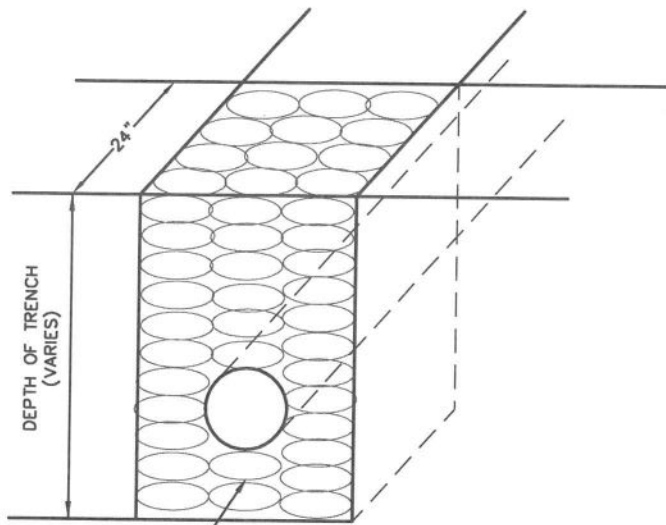

SEE TABLE 1 FOR TYPE OF PLUG MATERIALS

SECTION

TRENCH SLOPE (%)	'L' (FEET)	PLUG MATERIAL
0-5	*	** EARTH FILLED SACKS
5-15	500	** EARTH FILLED SACKS
15-25	300	** EARTH FILLED SACKS
25-35	200	** EARTH FILLED SACKS
35-100	100	** EARTH FILLED SACKS
> 100	50	CEMENT FILLED BAGS (WET) OR MORTARED STONE

* TRENCH PLUGS ARE REQUIRED AT ALL STREAM CROSSINGS, RIVER CROSSINGS, WATER-BODY CROSSINGS, OR WHERE INDICATED ON CONSTRUCTION PLANS REGARDLESS OF TRENCH SLOPE.

** TOPSOIL MAY NOT BE USED TO FILL SACKS.

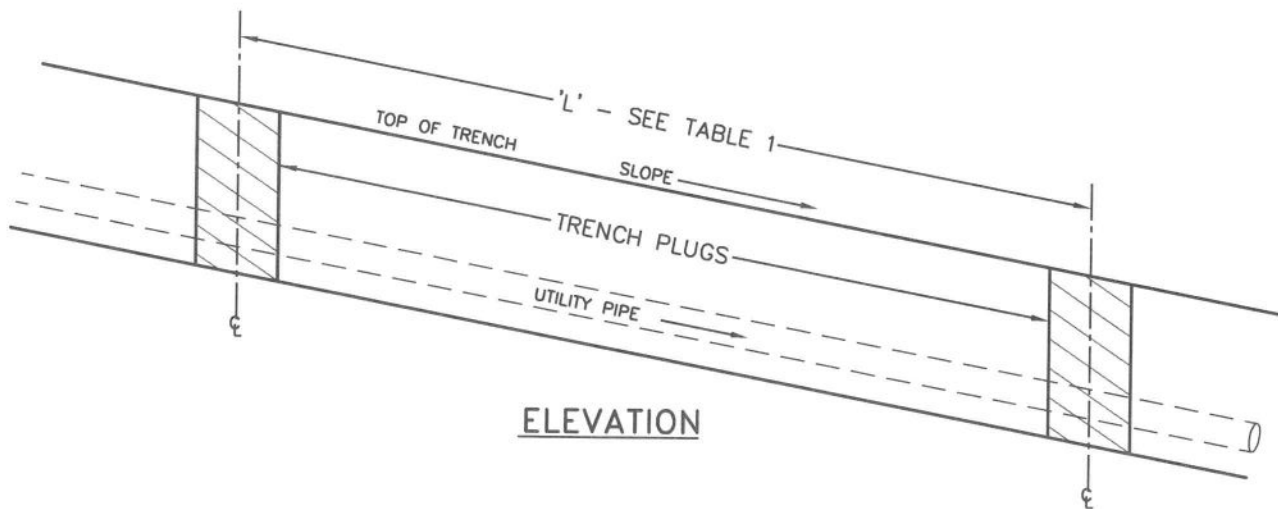

ELEVATION

**SANITARY SEWER
TRENCH PLUG DETAIL**

NIRA Consulting Engineers, Inc.

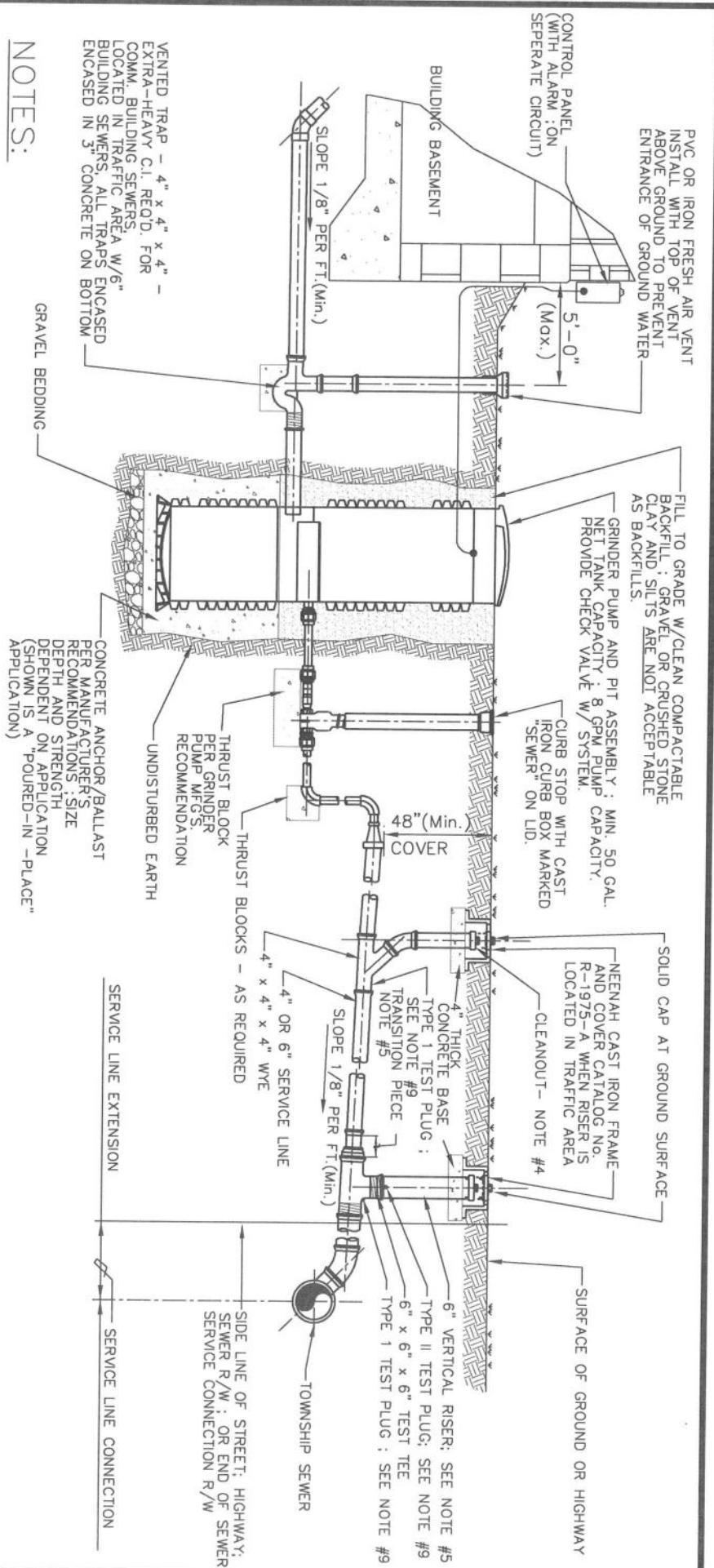

NOTES:

1. THE ENTIRE INSTALLATION MUST BE INSPECTED AND APPROVED BY THE AUTHORITY.
2. THE GRAVITY SANITARY SEWER LATERAL CONNECTION MUST BE INSTALLED IN ACCORDANCE WITH AUTHORITY RULES AND REGULATIONS.
3. BEFORE WORK IS STARTED, AN APPLICATION FOR SANITARY SEWER CONNECTION INSPECTION MUST BE FILED WITH THE AUTHORITY.
4. CLEANOUTS SHALL BE INSTALLED AT 50' MAXIMUM INTERVALS FOR 4" PIPE OR 100' MAXIMUM INTERVALS FOR 6" PIPE, AND AT CHANGES IN DIRECTION GREATER THAN 45°, AND WHEN DEPTH EXCEEDS 4'. VERTICAL RISER MUST BE INSTALLED AS REQUIRED BY AUTHORITY RULES AND REGULATIONS.
5. ALL GRAVITY PIPING & FITTINGS SHALL BE SDR 35 PVC OR SCH. 40 PVC, OR ABS SCH. 40, OR STD. WEIGHT CAST IRON.
6. ALL PRESSURE PIPING & FITTINGS SHALL BE MIN. 1 1/4" AND PRESSURE RATED TO SYSTEM PRESSURE WITH A SAFETY FACTOR OF NOT LESS THAN 1.5 AND SHALL BE FIELD PRESSURE TESTED.
7. ANY LINES INSTALLED IMPROPERLY OR COVERED WITHOUT INSPECTION BY THE AUTHORITY MUST BE REMOVED OR UNCOVERED AT THE PROPERTY OWNER'S EXPENSE.
8. ALL COMMERCIAL BUILDINGS SHALL BE MINIMUM 6" PIPE OR LARGER. ALL RESIDENTIAL BUILDINGS HAVE OPTION TO INSTALL 4" OR 6" PIPE.
9. INSTALL AIR INFLATABLE (TYPE I) DEADEND PLUGS IN FLOW LINE OF TEE AND WYE AS INDICATED, PROVIDE AIR INFLATABLE (TYPE II) TEST PLUG WITH FILL TUBE IN BRANCH OF TEE TO FACILITATE LOW PRESSURE AIR TEST. AIR TEST SHALL BE PASS / FAIL ONLY. TO SUCCESSFULLY PASS THE LOW PRESSURE AIR TEST THE SECTION OF THE LINE UNDER TEST MUST MAINTAIN AN INTERNAL PRESSURE OF 5 PSIG FOR 5 MINUTES WITH NO PRESSURE LOSS.

(PIPE SIZES AND PUMP MODELS FOR EQUIPMENT DEPENDENT ON APPLICATION)

**GRINDER PUMP TO GRAVITY
SANITARY SEWER MAIN**

NIRA Consulting Engineers, Inc.

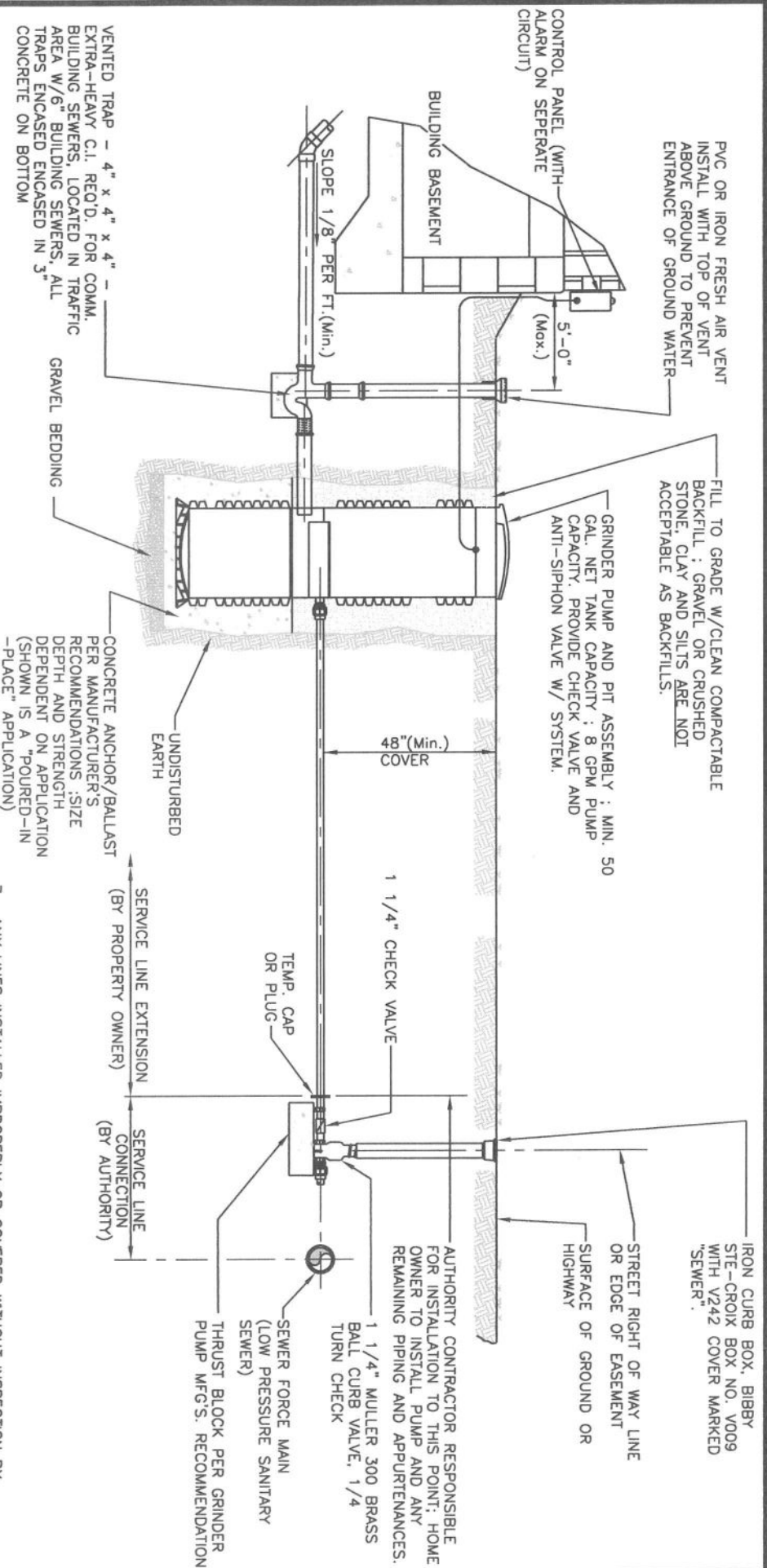

- NOTES:**
1. THE ENTIRE INSTALLATION MUST BE INSPECTED AND APPROVED BY THE AUTHORITY.
 2. THE GRAVITY SANITARY SEWER LATERAL CONNECTION MUST BE INSTALLED IN ACCORDANCE WITH AUTHORITY RULES AND REGULATIONS.
 3. BEFORE WORK IS STARTED, AN APPLICATION FOR SANITARY SEWER CONNECTION INSPECTION MUST BE FILED WITH THE AUTHORITY.
 4. CLEANOUTS SHALL BE INSTALLED AT 50' MAXIMUM INTERVALS FOR 4" PIPE OR 100' MAXIMUM INTERVALS FOR 6" PIPE, AND AT CHANGES IN DIRECTION GREATER THAN 45', AND WHEN DEPTH EXCEEDS 4'. VERTICAL RISER MUST BE INSTALLED AS REQUIRED BY AUTHORITY RULES AND REGULATIONS.
 6. ALL GRAVITY PIPING & FITTINGS SHALL BE SDR 35 PVC OR SCH. 40 PVC, OR ABS SCH. 40, OR STD. WEIGHT CAST IRON.
- ALL PRESSURE PIPING & FITTINGS SHALL BE MIN. 1 1/4" AND PRESSURE RATED TO SYSTEM PRESSURE WITH A SAFETY FACTOR OF NOT LESS THAN 1.5 AND SHALL BE FIELD PRESSURE TESTED.

GRINDER PUMP TO LOW PRESSURE SANITARY SEWER

NIRA Consulting Engineers, Inc.

7. ANY LINES INSTALLED IMPROPERLY OR COVERED WITHOUT INSPECTION BY THE AUTHORITY MUST BE REMOVED OR UNCOVERED AT THE PROPERTY OWNER'S EXPENSE.
8. ALL RESIDENTIAL BUILDINGS HAVE OPTION TO INSTALL 4" OR 6" PIPE.
9. INSTALL AIR INFLATABLE (TYPE I) DEADEND PLUGS IN FLOW LINE OF TEE AND WYE AS INDICATED. PROVIDE AIR INFLATABLE (TYPE II) TEST PLUG WITH FILL TUBE IN BRANCH OF TEE TO FACILITATE LOW PRESSURE AIR TEST. AIR TEST SHALL BE PASS / FAIL ONLY. TO SUCCESSFULLY PASS THE LOW PRESSURE AIR TEST THE SECTION OF THE LINE UNDER TEST MUST MAINTAIN AN INTERNAL PRESSURE OF 5 PSIG FOR 5 MINUTES WITH NO PRESSURE LOSS.

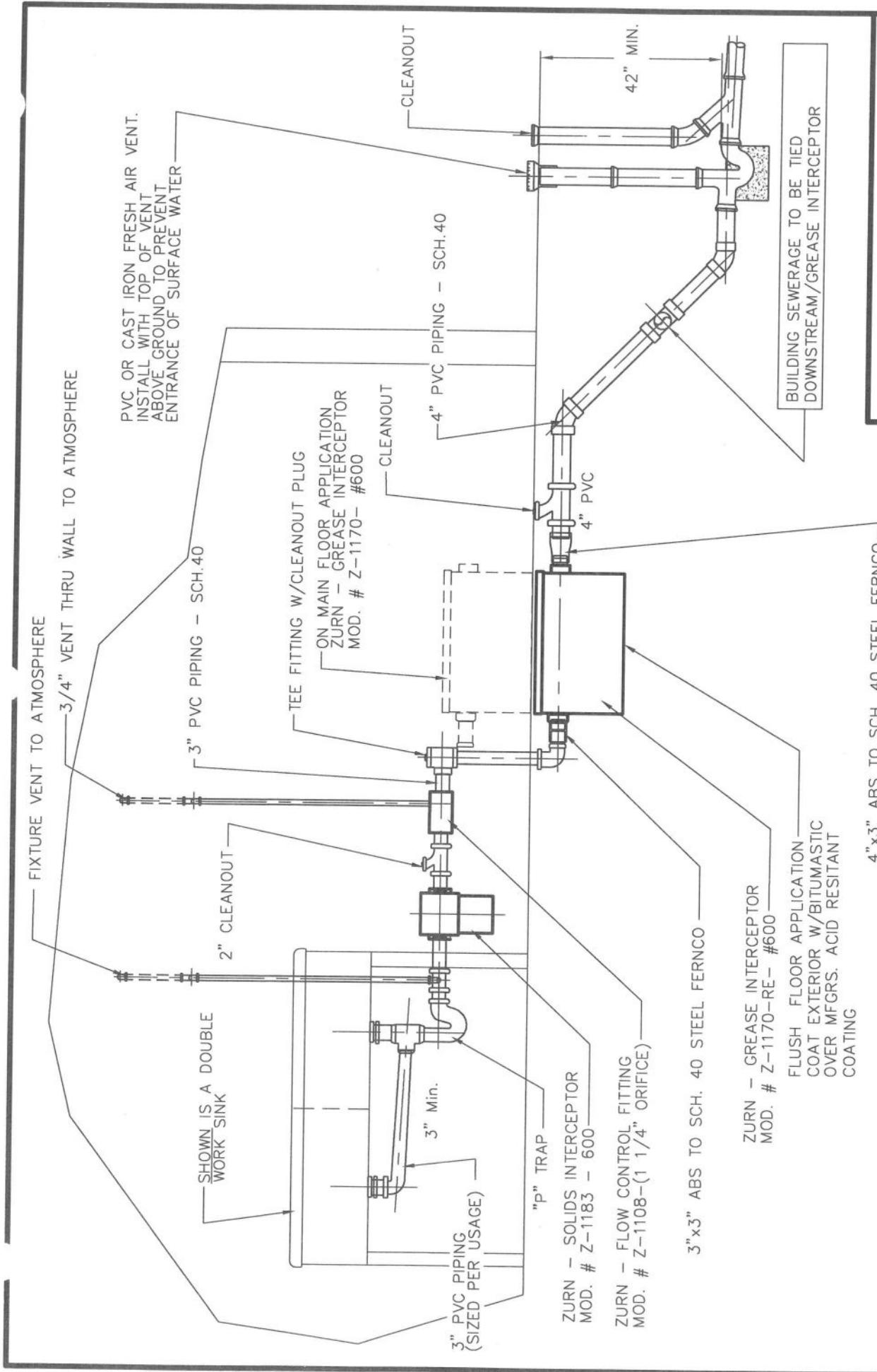

**GREASE INTERCEPTOR SYSTEM
(INSIDE BUILDING)**

(25 GPM USED AS EXAMPLE. ACTUAL SIZES AND MODELS FOR EQUIPMENT DEPENDENT ON APPLICATION)

NIRA Consulting Engineers, Inc.

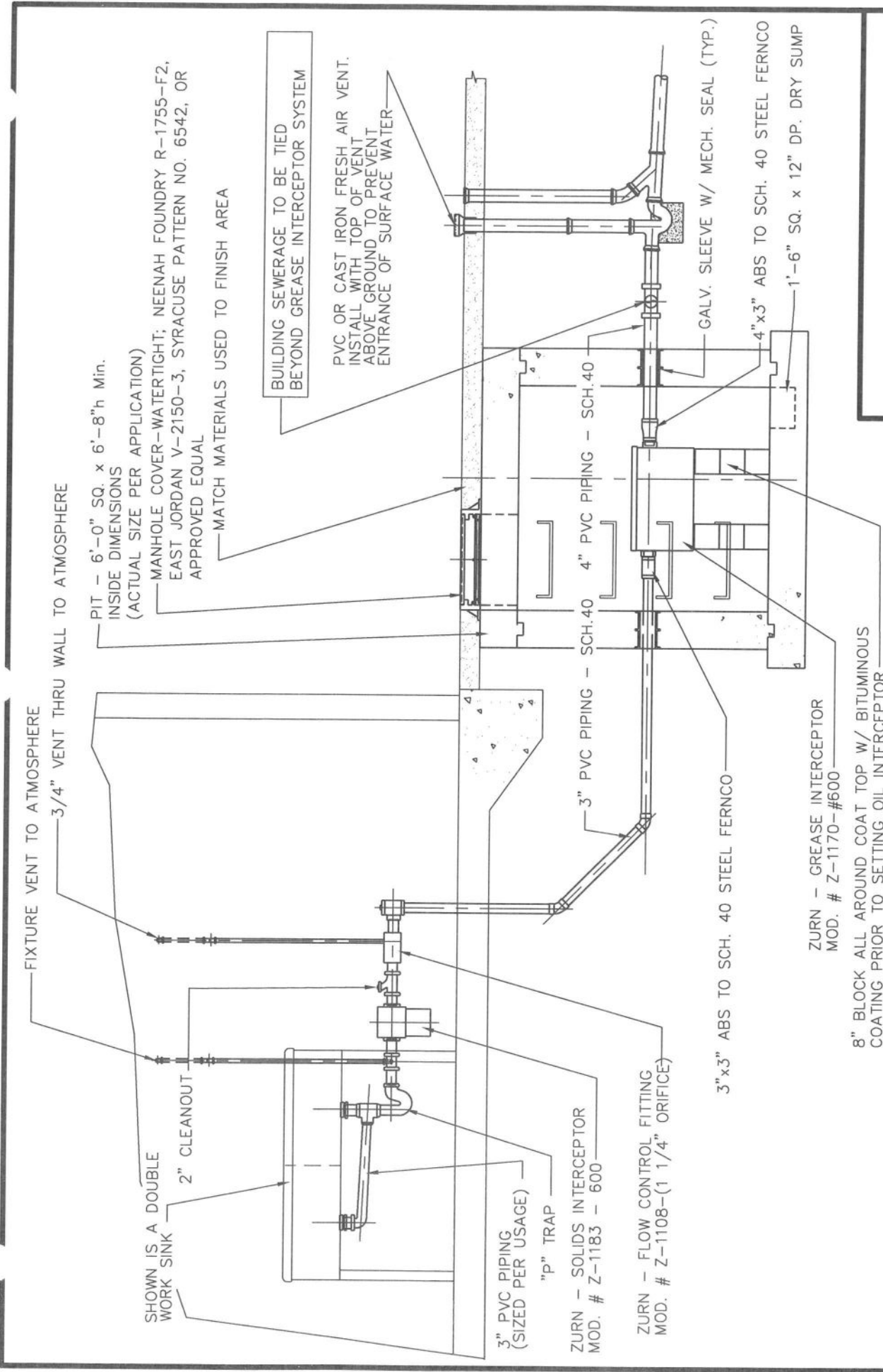

FIXTURE VENT TO ATMOSPHERE
3/4" VENT THRU WALL TO ATMOSPHERE

PIT - 6'-0" SQ. x 6'-8" h Min.
(ACTUAL DIMENSIONS
PER APPLICATION)

MANHOLE COVER-WATERTIGHT; NEENAH FOUNDRY R-1755-F2,
EAST JORDAN V-2150-3, SYRACUSE PATTERN NO. 6542, OR
APPROVED EQUAL

MATCH MATERIALS USED TO FINISH AREA

BUILDING SEWERAGE TO BE TIED
BEYOND GREASE INTERCEPTOR SYSTEM

PVC OR CAST IRON FRESH AIR VENT.
INSTALL WITH TOP OF VENT
ABOVE GROUND TO PREVENT
ENTRANCE OF SURFACE WATER

SHOWN IS A DOUBLE
WORK SINK

2" CLEANOUT

3" PVC PIPING
(SIZED PER USAGE)

"P" TRAP

ZURN - SOLIDS INTERCEPTOR
MOD. # Z-1183 - 600

ZURN - FLOW CONTROL FITTING
MOD. # Z-1108-(1 1/4" ORIFICE)

3"x3" ABS TO SCH. 40 STEEL FERENCO

ZURN - GREASE INTERCEPTOR
MOD. # Z-1170-#600

8" BLOCK ALL AROUND COAT TOP W/ BITUMINOUS
COATING PRIOR TO SETTING OIL INTERCEPTOR

**GREASE INTERCEPTOR SYSTEM
(OUTSIDE BUILDING)**

(25 GPM USED AS EXAMPLE. ACTUAL SIZES AND MODELS FOR EQUIPMENT DEPENDENT ON APPLICATION)

NIRA Consulting Engineers, Inc.

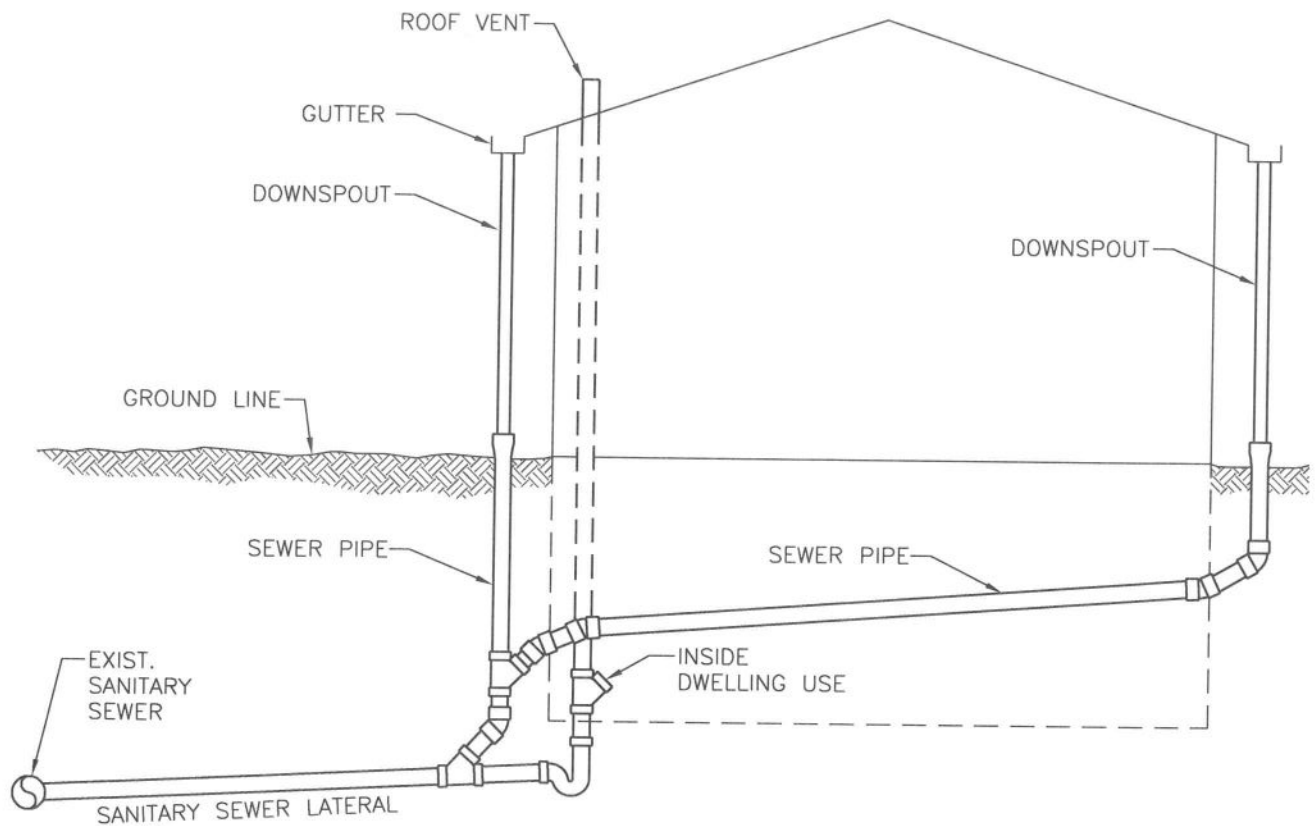

TYPICAL ROOF DRAIN DOWNSPOUT CONNECTION TO SANITARY SEWER (PROHIBITED)

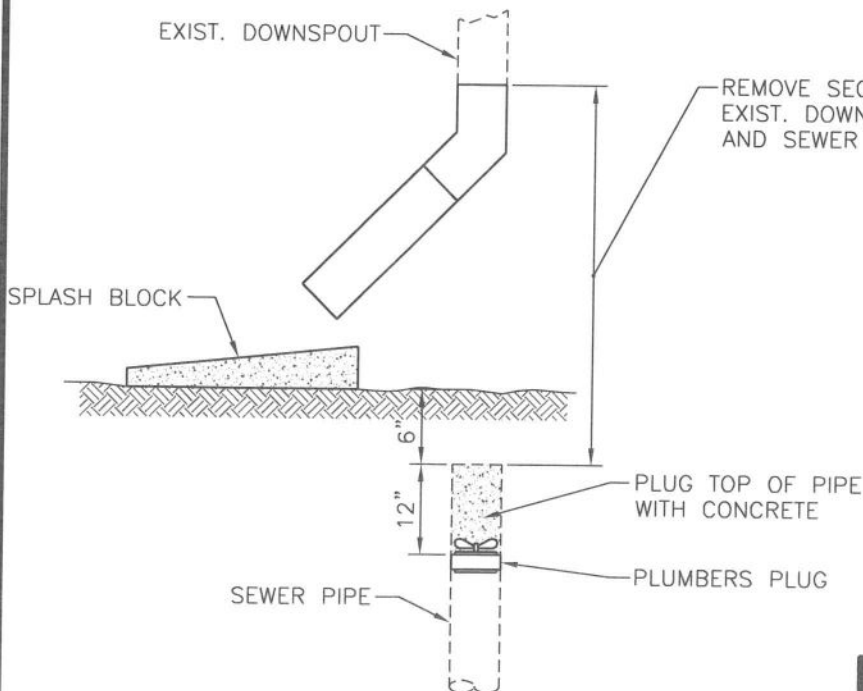

TYPICAL SECTION ROOF DRAIN DOWNSPOUT REMOVAL FROM SANITARY SEWERS

NOTES:

1. THE CONNECTION OF ROOF LEADERS TO SANITARY SEWERS IS PROHIBITED.
2. THE OWNER MUST, AT HIS EXPENSE, DISCONNECT ALL ROOF LEADERS FROM EXISTING SANITARY SEWERS.
3. ROOF LEADERS MAY BE CONNECTED TO EXISTING STORM SEWERS PROVIDED ONE EXISTS ON-LOT AND IS REASONABLY ACCESSIBLE.
4. ROOF LEADER DISCHARGE MUST BE ROUTED AS TO NOT CREATE A NUISANCE TO ADJOINING PROPERTIES, SIDEWALKS, OR STREETS.

DOWNSPOUT REMOVAL FROM SANITARY SEWERS

NIRA Consulting Engineers, Inc.

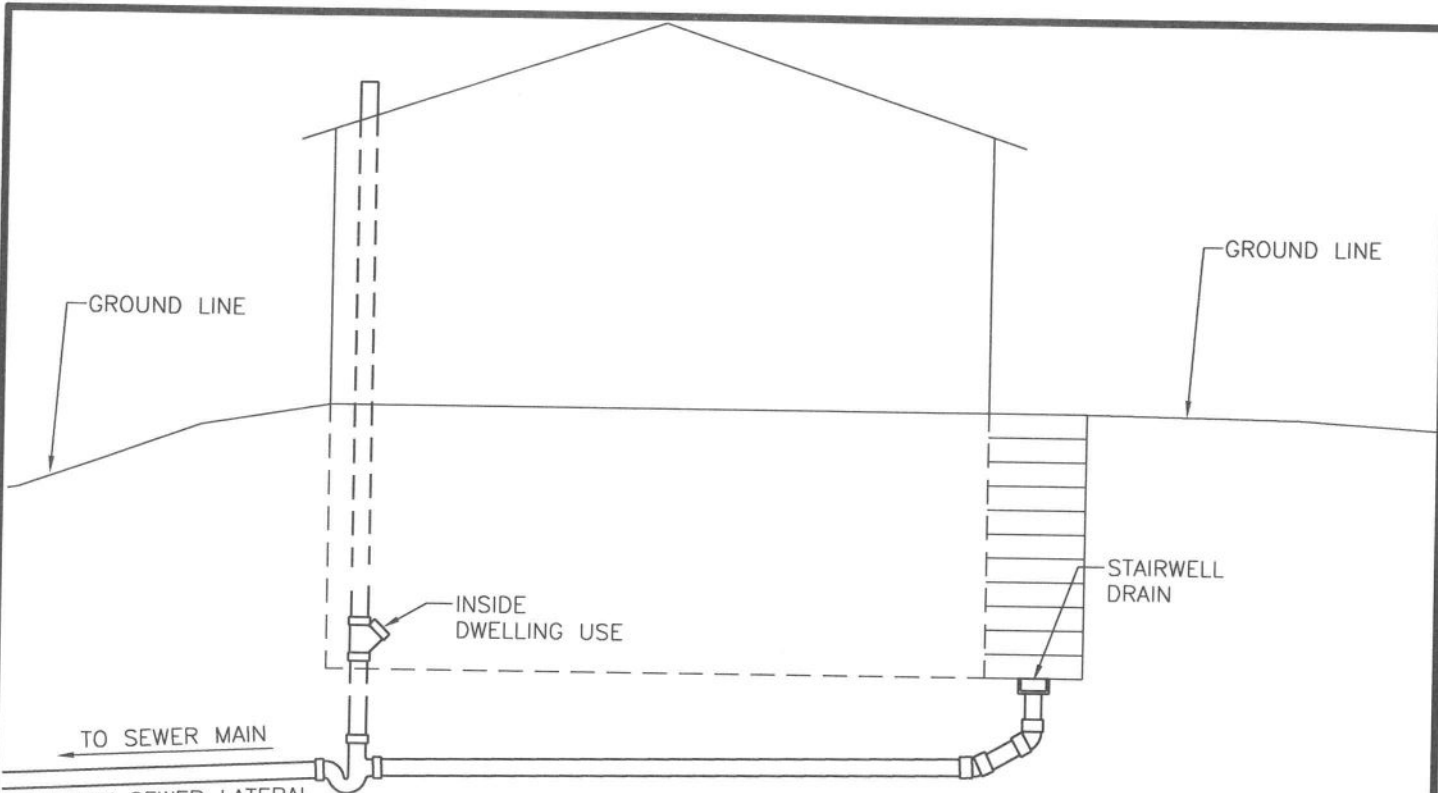

TYPICAL STAIRWELL DRAIN CONNECTION TO SANITARY SEWER (PROHIBITED)

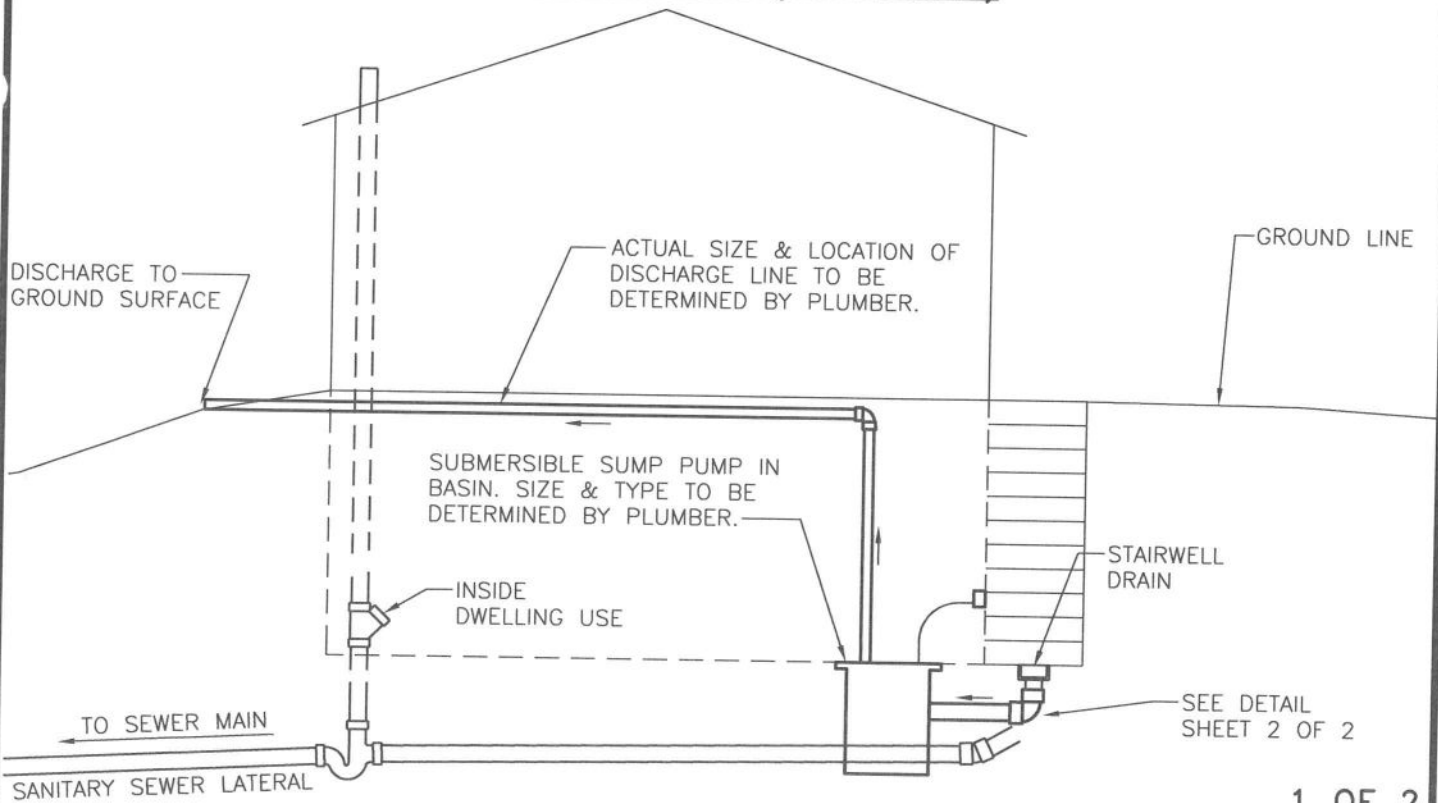

TYPICAL STAIRWELL DRAIN DISCONNECTION WITH SUMP PUMP INSTALLATION

STAIRWELL DRAIN REMOVAL FROM SANITARY SEWERS

NIRA Consulting Engineers, Inc.

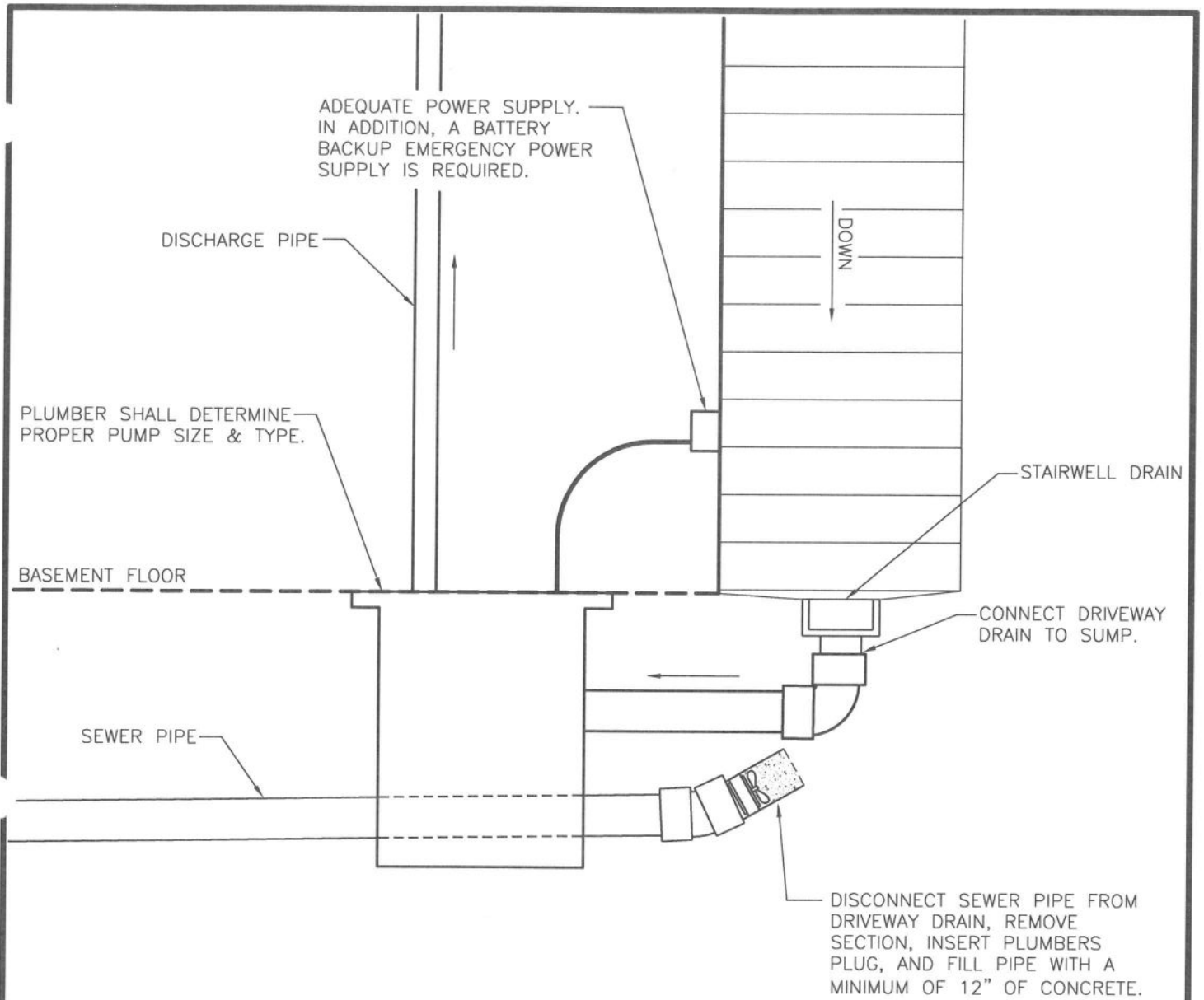

STAIRWELL DRAIN TO SUMP PUMP DETAIL

NOTES:

1. THE CONNECTION OF STAIRWELL DRAINS TO SANITARY SEWERS IS PROHIBITED.
2. THE OWNER MUST, AT HIS EXPENSE, DISCONNECT ALL STAIRWELL DRAINS FROM EXISTING SANITARY SEWERS.
3. STAIRWELL DRAINS MAY DISCHARGE INTO EXISTING STORM SEWERS PROVIDED ONE EXISTS ON-LOT AND IS REASONABLY ACCESSIBLE.
4. SUMP PUMP DISCHARGE MUST BE ROUTED AS TO NOT CREATE A NUISANCE TO ADJOINING PROPERTIES, SIDEWALKS, OR STREETS.

2 OF 2

**STAIRWELL DRAIN REMOVAL
FROM SANITARY SEWERS**

NIRA Consulting Engineers, Inc.

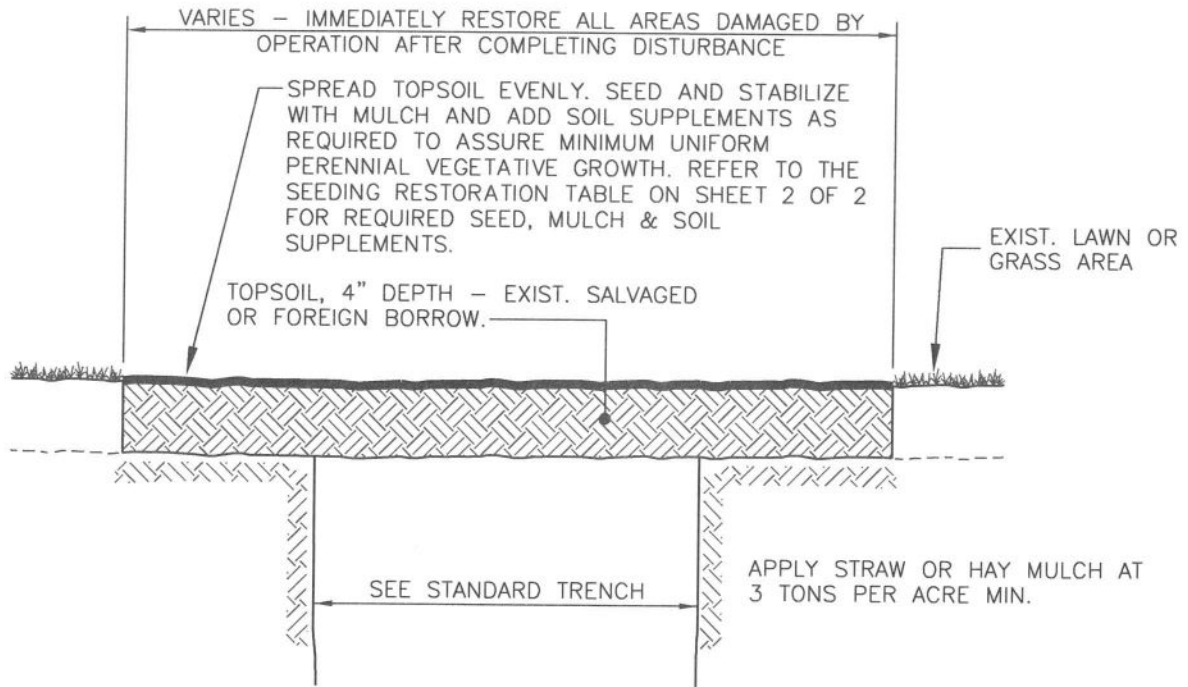

MULCH APPLICATION RATES

MULCH TYPE	APPLICATION RATE (Min.)			NOTES
	PER ACRE	PER 1,000 SFT.	PER 1,000 SYD.	
STRAW	3 tons	140 lb.	1,240 lb.	Either wheat or oat straw, free of weeds, not chopped or finely broken.
HAY	3 tons	140 lb.	1,240 lb.	Timothy, mixed clover and timothy, or other native forage grasses.
WOOD CELLULOSE	1,500 lb.	35 lb.	310 lb.	Do not use alone in winter, during hot and dry weather, or on steep slopes (greater than 3:1).
WOOD	1,000 lb. cellulose	25 lb.	210 lb.	When used over straw or hay.
WOOD CHIPS	4 to 6 ton	185 to 275 lb.	1,650 to 2,500 lb.	May prevent germination of grasses and legumes.

SEED REQUIREMENTS

SPECIES	MINIMUM GUARANTEED PURITY (PERCENT)	MAXIMUM WEED SEED (PERCENT)	MINIMUM GUARANTEED GERMINATION (PERCENT)
Kentucky Bluegrass (<i>Poa pratensis</i>) Domestic origin; min. 21 lb. Per Bushel	90	0.20	80
Perennial Ryegrass (<i>Lolium perenne</i> , var. Pennfine)	95	0.15	90
Kentucky 31 Fescue (<i>Festuca elatior arundinacea</i>)	98	0.25	85
Crownvetch (<i>Coronilla varia</i> , var. Penngift)	99	0.10	70
Pennlawn Red Fescue (<i>Festuca rubra</i> , var. Pennlawn)	98	0.25	90
Annual Rye Grass (<i>Lolium multiflorum</i>)	95	0.25	95
Timothy (<i>Phleum pratense</i>)	98	0.25	95

1 OF 2

PERMANENT VEGETATIVE RESTORATION DETAIL

NIRA Consulting Engineers, Inc.

SEEDING RESTORATION TABLE

RESTORATION CONDITION	TOPSOIL	LIME*	BASIC FERTILIZER	STARTER FERTILIZER	SEED MIX & SOWING RATE (% BY WEIGHT)
Temporary cover	N/A	N/A	N/A	N/A	100% Annual Ryegrass, Sow 9# per 1000 Sq. Yds., Mar. thru May/Aug. thru Sept.
Roadside; Non-mowed (All Disturbed Flat Areas Outside Fence)	Yes	100# per 1000 Sq. Ft.	No	10-5-5 @ 50# per 1000 Sq. Ft. or 12-6-6 @ 33# per 1000 Sq. Ft.	80% Kentucky 31, Fescue; 20% Pennlawn Red Fescue Sow 21# per 1000 Sq. Yds., Mar. thru May/Aug. thru Sept.
Roadside; Mowed	Yes	100# per 1000 Sq. Ft.	No	10-5-5 @ 50# per 1000 Sq. Ft. or 12-6-6 @ 33# per 1000 Sq. Ft.	50% Kentucky Bluegrass; 30% Pennlawn Red Fescue; 20% Perennial Ryegrass Sow 21# per 1000 Sq. Yds. Mar. thru May/Aug. thru Sept.
Bank Areas (All Vegetated Lagoon Berms)	Yes	100# per 1000 Sq. Ft.	No	10-5-5 @ 50# per 1000 Sq. Ft. or 12-6-6 @ 33# per 1000 Sq. Ft.	45% Crown-vetch; 55% Annual Ryegrass; Sow 9# per 1000 Sq. Yds., Anytime except Sept. & Oct.
Lawns	Yes	100# per 1000 Sq. Ft.	10-20-20 @ 50# per 1000 Sq. Ft.	10-5-5 @ 50# per 1000 Sq. Ft. or 12-6-6 @ 33# per 1000 Sq. Ft.	50% Kentucky Bluegrass; 30% Pennlawn Red Fescue; 20% Perennial Ryegrass Sow 21# per 1000 Sq. Yds. Mar. thru May/Aug. thru Sept.
Open Fields Non-Cultivated, Pasture	No	No	No	10-5-5 @ 50# per 1000 Sq. Ft. or 12-6-6 @ 33# per 1000 Sq. Ft.	100% Timothy Sow 9# per 1000 Sq. Yds., Mar. thru May/Aug. thru Sept.
Open Fields Cultivated	No	No	No	10-5-5 @ 50# per 1000 Sq. Ft. or 12-6-6 @ 33# per 1000 Sq. Ft.	100% Annual Ryegrass, Sow 9# per 1000 Sq. Yds., Mar. thru May/Aug. thru Sept.
Woods; Sparse	No	No	No	10-5-5 @ 50# per 1000 Sq. Ft. or 12-6-6 @ 33# per 1000 Sq. Ft.	100% Red Fescue; Sow 35# per 1000 Sq. Yds.; Mar. thru May/Aug. thru Sept.

2 OF 2

**PERMANENT VEGETATIVE
RESTORATION DETAIL**

NIRA Consulting Engineers, Inc.

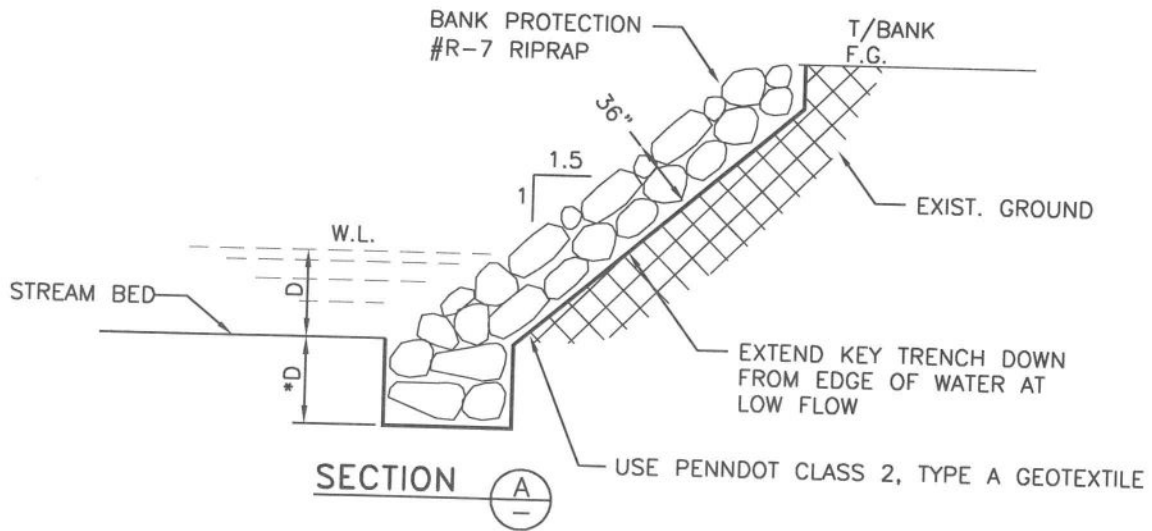
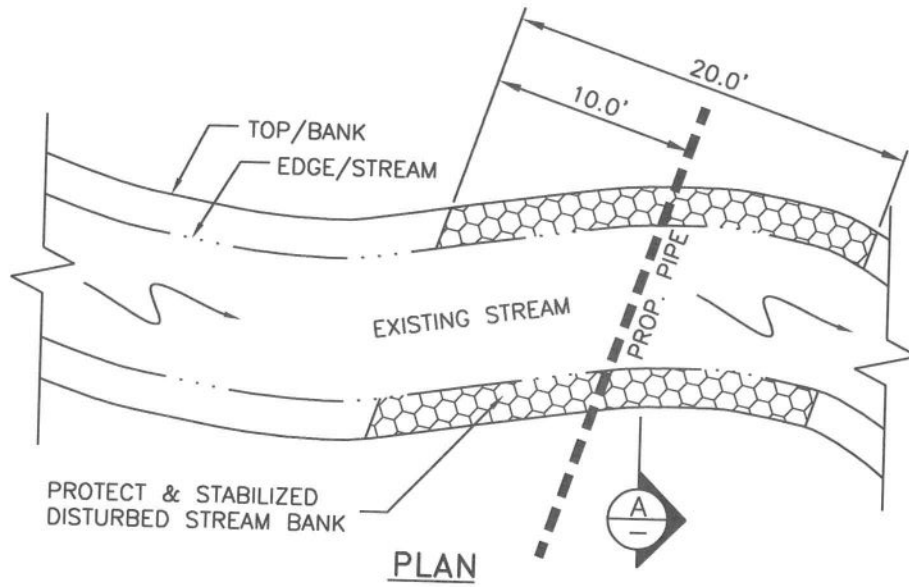

* MATCH DEPTH OF STREAM OR 2 V.F. WHICHEVER IS GREATER.

**STREAM BANK PROTECTION
DETAIL**

NIRA Consulting Engineers, Inc.

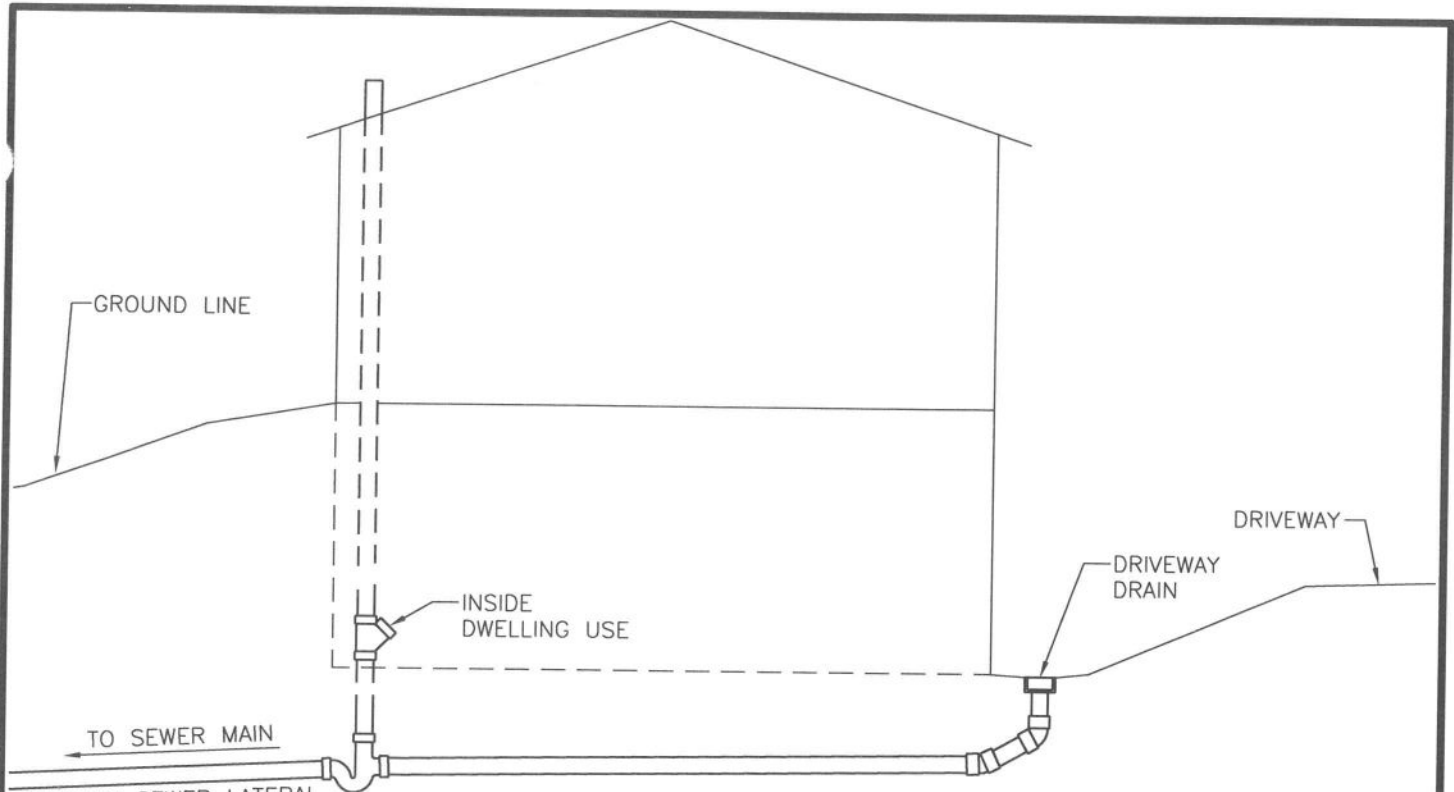

**TYPICAL DRIVEWAY DRAIN CONNECTION TO
SANITARY SEWER (PROHIBITED)**

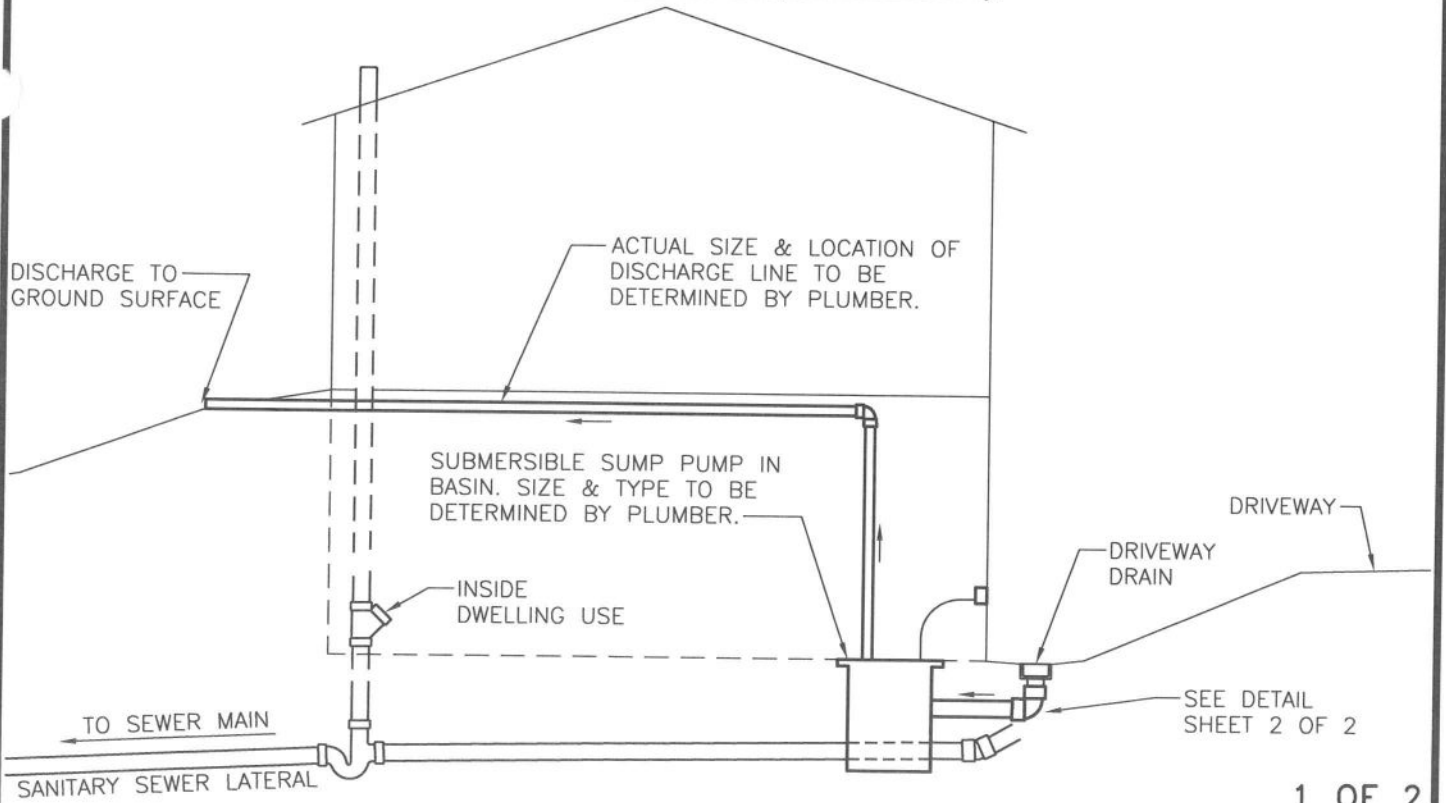

**TYPICAL DRIVEWAY DRAIN DISCONNECTION
WITH SUMP PUMP INSTALLATION**

**DRIVEWAY DRAIN REMOVAL
FROM SANITARY SEWERS**

NIRA Consulting Engineers, Inc.

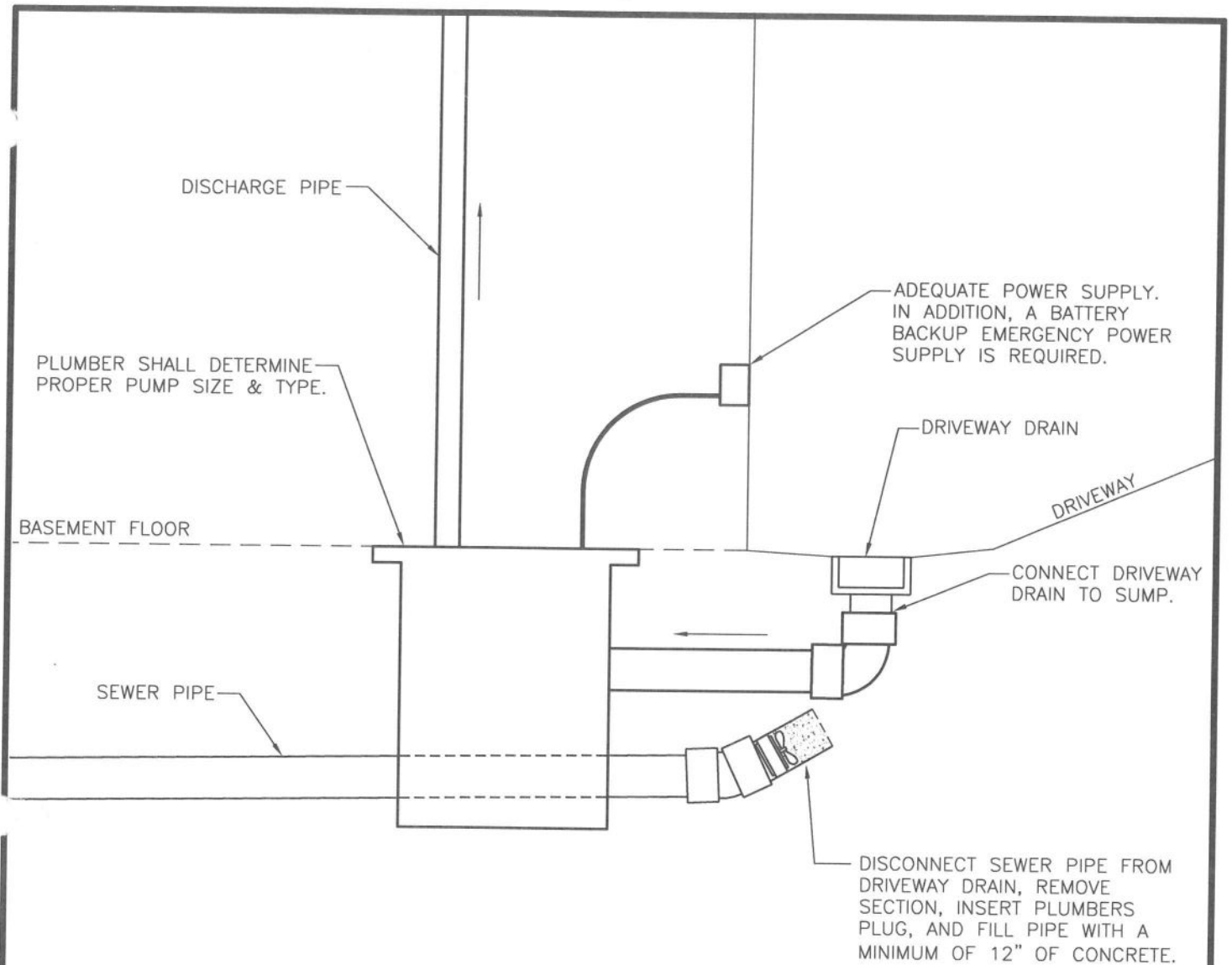

DRIVEWAY DRAIN TO SUMP PUMP DETAIL

NOTES:

1. THE CONNECTION OF DRIVEWAY DRAINS TO SANITARY SEWERS IS PROHIBITED.
2. THE OWNER MUST, AT HIS EXPENSE, DISCONNECT ALL DRIVEWAY DRAINS FROM EXISTING SANITARY SEWERS.
3. DRIVEWAY DRAINS MAY DISCHARGE INTO EXISTING STORM SEWERS PROVIDED ONE EXISTS ON-LOT AND IS REASONABLY ACCESSIBLE.
4. SUMP PUMP DISCHARGE MUST BE ROUTED AS TO NOT CREATE A NUISANCE TO ADJOINING PROPERTIES, SIDEWALKS, OR STREETS.

2 OF 2

**DRIVEWAY DRAIN REMOVAL
FROM SANITARY SEWERS**

NIRA Consulting Engineers, Inc.